



Operating Instructions
optoNCDT 1220

ILD1220-10

ILD1220-25

ILD1220-50

ILD1220-100

ILD1220-200

ILD1220-500

Intelligent laser-optical displacement measurement

MICRO-EPSILON MESSTECHNIK
GmbH & Co. KG
Koenigbacher Str. 15

94496 Ortenburg / Germany

Tel: +49 (0) 8542 / 168-0
Fax: +49 (0) 8542 / 168-90
info@micro-epsilon.com
<https://www.micro-epsilon.com>

Contents

1	Safety.....	6
1.1	Symbols used.....	6
1.2	Warnings.....	6
1.3	Notes on product marking.....	6
1.3.1	CE marking.....	6
1.3.2	UKCA marking.....	7
1.4	Intended use.....	7
1.5	Proper environment.....	7
2	Laser Safety.....	8
3	Functional principle, technical data.....	9
3.1	Brief description.....	9
3.2	Intelligent surface control.....	9
3.3	Technical data.....	10
4	Delivery.....	11
4.1	Unpacking, included in delivery.....	11
4.2	Storage.....	11
4.3	Structure of the serial number.....	11
5	Installation.....	12
5.1	Notes on operation.....	12
5.1.1	Reflectance of target surface.....	12
5.1.2	Error influences.....	12
5.1.2.1	Ambient light.....	12
5.1.2.2	Color differences.....	12
5.1.2.3	Temperature Influences.....	12
5.1.2.4	Mechanical vibrations.....	12
5.1.2.5	Movement blur.....	13
5.1.2.6	Surface Roughness.....	13
5.1.2.7	Angular influences.....	13
5.1.3	Optimization of measurement accuracy.....	13
5.2	Mechanical fastening, dimensional drawing.....	14
5.3	Control and indicator elements.....	15
5.4	Electrical connections.....	16
5.4.1	Connection options for parameterization.....	16
5.4.2	Pin assignment.....	16
5.4.3	Supply voltage.....	17
5.4.4	Turning on the Laser.....	17
5.4.5	RS422 connection with USB converter IF2001/USB.....	17
5.4.6	Analog output.....	18
5.4.7	Multifunction input.....	18
5.4.8	Switching output.....	18
5.4.9	Sensor cable.....	19
6	Operation.....	20
6.1	Getting Ready for Operation.....	20
6.2	Parameterization via web interface.....	20
6.2.1	Requirements.....	20
6.2.2	Access via web interface.....	21
6.2.3	Calibration protocol.....	22
6.3	Programming via ASCII Commands.....	22
6.4	Time response, measurement value flow.....	22
7	Set sensor parameters, web interface.....	23
7.1	Preliminary remarks concerning the setting options.....	23
7.2	Overview of parameters.....	23
7.3	Inputs.....	23
7.3.1	Overview of functions.....	23
7.3.2	Zeroing.....	23
7.3.2.1	Zeroing with the Select button.....	24
7.3.2.2	Zeroing via hardware input.....	24
7.4	Signal Processing.....	25

7.4.1	Preliminary remark.....	25
7.4.2	Measuring rate.....	25
7.4.3	Error Handling.....	25
7.4.4	Triggering.....	25
7.4.4.1	General.....	25
7.4.4.2	Triggering the output of measurement values.....	26
7.5	Outputs.....	26
7.5.1	Overview.....	26
7.5.2	Digital output, RS422.....	27
7.5.2.1	Values, Ranges.....	27
7.5.2.2	Behavior of the Digital Output.....	28
7.5.3	Analog output.....	30
7.5.3.1	Output scaling.....	30
7.5.3.2	Output scaling with the Select button.....	31
7.5.3.3	Output Scaling via Hardware Input.....	31
7.5.3.4	Calculation of measured value from analog current.....	32
7.5.3.5	Behavior Distance Value and Analog Output.....	32
7.5.3.6	Analog output, zeroing and teaching.....	33
7.5.4	Error output.....	34
7.5.5	Data Output.....	35
7.6	System Settings.....	35
7.6.1	General.....	35
7.6.2	Unit, language.....	36
7.6.3	Key Lock.....	36
7.6.4	Loading, saving.....	36
7.6.5	Import, Export.....	37
7.6.6	Access Authorization.....	37
7.6.7	Resetting the sensor.....	38
8	Digital interface RS422.....	39
8.1	Preliminary remarks.....	39
8.2	Measurement data format.....	39
8.3	Conversion of the binary data format.....	39
9	Cleaning.....	40
10	Software support with MEDAQLib.....	41
11	Disclaimer.....	42
12	Service, repair.....	43
13	Decommissioning, disposal.....	44
14	Optional accessories.....	45
15	Factory settings.....	46
16	ASCII communication with sensor.....	47
16.1	General.....	47
16.2	Commands overview.....	48
16.3	Commands.....	49
16.3.1	General commands.....	49
16.3.1.1	HELP.....	49
16.3.1.2	GETINFO, Sensor Information.....	50
16.3.1.3	LANGUAGE, Website.....	50
16.3.1.4	RESET, Booting sensor.....	50
16.3.1.5	ECHO, Switching the Command Reply, ASCII Interface.....	50
16.3.1.6	PRINT, Sensor Settings.....	50
16.3.2	User level.....	51
16.3.2.1	LOGIN, Change of the User Level.....	51
16.3.2.2	LOGOUT, Change into User Level.....	51
16.3.2.3	GETUSERLEVEL, User level query.....	51
16.3.2.4	STDUSER, Set Standard User.....	51
16.3.2.5	PASSWD, Change Password.....	51
16.3.3	Triggering.....	51
16.3.3.1	TRIGGER, Trigger selection.....	51
16.3.3.2	MFILELEVEL, Input Level Multi-Function Input.....	52
16.3.3.3	TRIGGERCOUNT, Number of Output Measurement Values.....	52





16.3.4	Interfaces.....	52
16.3.4.1	BAUDRATE, RS422.....	52
16.3.4.2	UNIT, Measurement unit of web interface.....	52
16.3.4.3	MFIFUNC, Function selection multifunction input.....	52
16.3.4.4	ERROROUT1, Activate switching output.....	52
16.3.4.5	ERRORLEVELOUT1, Output level switching output.....	52
16.3.4.6	ERRORLIMIT.....	53
16.3.4.7	ERRORHYSTERESIS.....	53
16.3.4.8	ERROROUTHOLD.....	53
16.3.5	Handling of setups.....	53
16.3.5.1	IMPORT.....	53
16.3.5.2	EXPORT.....	53
16.3.5.3	MEASSETTINGS, Load / Save Measurement Settings.....	53
16.3.5.4	BASICSETTINGS, Load/Save Device Settings.....	54
16.3.5.5	SETDEFAULT, factory settings	54
16.3.6	ANALOGSCALE, Scaling the analog output.....	54
16.3.7	Key function.....	55
16.3.7.1	KEYFUNC, Select key function.....	55
16.3.7.2	KEYLOCK, Set Keylock.....	55
16.3.8	Measurement.....	55
16.3.8.1	MEASRATE, Measuring rate.....	55
16.3.8.2	LASERPOW, Laser Power.....	55
16.3.8.3	MASTERMV, Mastering / zeroing.....	55
16.3.9	Data Output.....	56
16.3.9.1	OUTPUT, Selection of Measurement Value Output.....	56
16.3.9.2	OUTHOLD, Error Handling.....	56
16.3.9.3	GETOUTINFO_RS422, Data Selection Query.....	56
16.3.9.4	OUT_RS422.....	56
16.3.9.5	OUTADD_RS422, Data Selection of Additional Values.....	56
16.4	Error Messages.....	56
	Index.....	58

1 Safety

1.1 Symbols used

System operation assumes knowledge of the operating instructions.

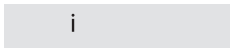
The following symbols are used in these operating instructions:



 CAUTION	Indicates a hazardous situation which, if not avoided, may result in minor or moderate injury.
 NOTICE	Indicates a situation that may result in property damage if not avoided.
	Indicates a user action.
 i	Indicates a tip for users.
 Measurement	Indicates hardware or a software button/menu.

1.2 Warnings

Do not expose yourself to unnecessary laser radiation.

- ▶ Switch off the sensor for cleaning and maintenance.
- ▶ Switch off the sensor for cleaning and maintenance if the sensor is integrated into a system.

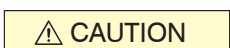
Caution - the use of controls or settings or the performance of procedures not specified in the operating instructions may cause damage.

 CAUTION	<p>Connect the power supply according to the regulations for electrical equipment.</p> <ul style="list-style-type: none"> • Risk of injury • Damage to or destruction of the sensor
 NOTICE	<p>Avoid knocks and impacts to the sensor.</p> <ul style="list-style-type: none"> • Damage to or destruction of the sensor <p>Only attach the sensor to the existing mounting holes/threaded holes on a flat surface; clamping of any kind is not permitted.</p> <ul style="list-style-type: none"> • Damage to or destruction of the sensor <p>The supply voltage must not exceed the specified limits.</p> <ul style="list-style-type: none"> • Damage to or destruction of the sensor <p>Protect the sensor cable from damage. Attach the cable load-free, catch the cable after approx. 25 cm and catch the pigtail on the plug, e.g. with cable ties.</p> <ul style="list-style-type: none"> • Destruction of the sensor • Failure of the measuring device <p>Avoid constant exposure of the sensor to splashes of water.</p> <ul style="list-style-type: none"> • Damage to or destruction of the sensor <p>Avoid exposure of sensor to aggressive media (detergents, cooling emulsions).</p> <ul style="list-style-type: none"> • Damage to or destruction of the sensor

1.3 Notes on product marking

1.3.1 CE marking

The following apply to the product:

- Directive 2014/30/EU ("EMC")
- Directive 2011/65/EU ("RoHS")

Products which carry the CE marking satisfy the requirements of the EU Directives cited and the relevant applicable harmonized European standards (EN).

The product is designed for use in industrial and laboratory environments.

The EU Declaration of Conformity and the technical documentation are available to the responsible authorities according to the EU Directives.

1.3.2 UKCA marking

The following apply to the product:

- SI 2016 No. 1091 ("EMC")
- SI 2012 No. 3032 ("RoHS")

Products which carry the UKCA marking satisfy the requirements of the directives cited and the relevant applicable harmonized standards.

The product is designed for use in industrial and laboratory environments.

The UKCA Declaration of Conformity and the technical documentation are available to the responsible authorities according to the UKCA Directives.

1.4 Intended use

The optoNCDT 1220 is designed for use in industrial and laboratory applications.

It is used for

- Displacement, distance, position and thickness measurements
- Monitoring Quality and Checking Dimensions

The sensor must only be operated within the values specified in the technical data, [see Chap. 3.3](#).

The sensor must be used in such a way that no persons are endangered and no machines or other physical items of property are damaged in the event of malfunction or total failure of the sensor.

Take additional precautions for safety and damage prevention in case of safety-related applications.

1.5 Proper environment

Protection class: IP67 (only applies when the sensor cable is connected)

i The protection class is limited to water (no penetrating liquids, detergents, or similar aggressive media).

Optical windows are excluded from the protection class. Contamination of the windows causes impairment or failure of the function.

Temperature range:

- Operation:	0 ... +50 °C
- Storage:	-20 ... +70 °C
Humidity:	5 ... 95 % RH (non-condensing)
Ambient pressure:	Atmospheric pressure

2 Laser Safety

The sensor works with a semiconductor laser at a wavelength of 670 nm (visible/red).

The sensors fall within laser class 2. The laser is operated in pulsed mode, the maximum optical power is ≤ 1 mW. The pulse frequency depends on the set measuring rate (0.25 ... 2 kHz). The pulse duration of the peaks is controlled depending on the measuring rate and the reflectivity of the object being measured and can be 0.3 ... 3999.6 μ s.

 CAUTION
Laser radiation. Eyes could become irritated or damaged. Close your eyes, or immediately turn away if the laser beam hits the eye.

- i Observe the national laser protection regulations.

Relevant regulations must be observed when operating the sensors. The following apply accordingly:

- With class 2 laser devices, the eye is not endangered by random, brief exposure to laser radiation, i.e. exposure times of up to 0.25 s.
- Class 2 laser devices may therefore be used without further protective measures if you do not intentionally look into the laser beam or into specular-reflected radiation for more than 0.25 s.
- Because the presence of the eyelid protective reflex should not normally be assumed, one should deliberately close the eyes or turn away immediately if the laser beam hits the eye.

Lasers of Class 2 are not subject to notification and a laser protection officer is not required.

The two laser warning signs (German / English) are attached to the sensor cable:



Fig. 2.1: Laser warning signs on the sensor cable



Fig. 2.2: Laser warning sign on the sensor housing

- i If both information signs are covered over when the unit is installed, the user must ensure that supplementary information signs are attached at the installation location.

Operation of the laser is indicated visually by the LED on the sensor, [see Chap. 5.3](#).

The housings of the optical sensors may only be opened by the manufacturer, [see Chap. 11](#).

For repair and service purposes, the sensors must always be sent to the manufacturer.

Observe national regulations, e.g. the German Occupational Health and Safety Ordinance on Artificial Optical Radiation (OStrV).

Recommendations for the operation of sensors that emit laser radiation in the visible or non-visible range can be found in DIN EN 60825-1 (from 07/2022), among others.

3 Functional principle, technical data

3.1 Brief description

The optoNCDT 1220 operates according to the principle of optical triangulation, i.e. a visible, modulated light spot is projected onto the surface of the measuring object.

The diffuse part of the reflection of this light spot is imaged on a spatial resolution element (CMOS) by a receiver optic arranged at a certain angle to the optical axis of the laser beam.

A signal processor in the sensor calculates the distances between the light spot on the target and the sensor from the output signal of the CMOS element. The distance value is linearized and output via the analog or RS422 interface.

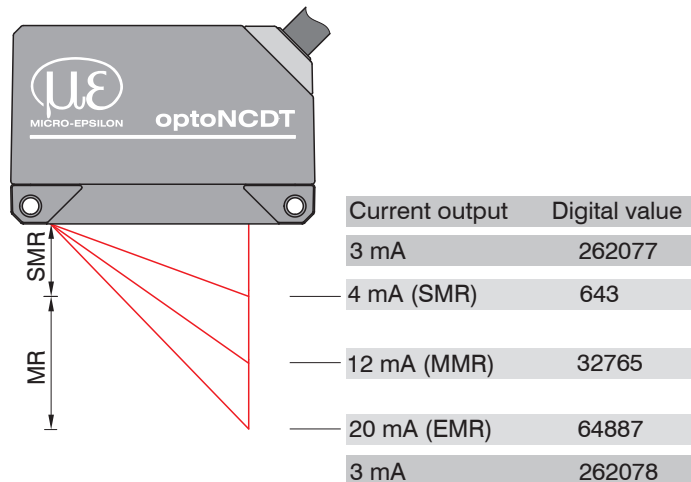

Fig. 3.1: Term Definitions

- MR* = Measuring range
- SMR* = Start of measuring range
- MMR* = Mid of measuring range
- EMR* = End of measuring range

The digital values apply to distance values without zeroing or mastering.

3.2 Intelligent surface control

Active Surface Compensation (ASC) enables stable compensation regardless of the color and brightness of the measured object. Thanks to the small measurement spot, even the smallest objects can be reliably detected.

3.3 Technical data

Model		ILD1220-10	ILD1220-25	ILD1220-50	ILD1220-100	ILD1220-200	ILD1220-500
Measuring range		10 mm	25 mm	50 mm	100 mm	200 mm	500 mm
Start of measuring range		20 mm	25 mm	35 mm	50 mm	60 mm	100 mm
Mid of measuring range		25 mm	37.5 mm	60 mm	100 mm	160 mm	350 mm
End of measuring range		30 mm	50 mm	85 mm	150 mm	260 mm	600 mm
Measuring rate ^[1]		4 adjustable stages: 2 kHz / 1 kHz / 0.5 kHz / 0.25 kHz					
Linearity ^[2]		< ±10 µm	< ±25 µm	< ±50 µm	< ±100 µm	< ±200 µm	< ±750 µm ... 1500 µm
		< ±0.10 % FSO					
Repeatability ^[3]		1 µm	2.5 µm	5 µm	10 µm	20 µm	50 µm
Temperature stability ^[4]		±0.015 % FSO / K			±0.01 % FSO / K		
Light spot diameter ^[5]	SMR	100 x 130 µm	200 x 260 µm	250 x 340 µm	710 x 910 µm	710 x 910 µm	710 x 910 µm
	MMR	45 x 50 µm	55 x 60 µm	80 x 95 µm			
	EMR	158 x 200 µm	255 x 330 µm	300 x 380 µm			
	smallest Ø	45 x 40 µm with 24 mm	53 x 60 µm with 31 mm	70 x 85 µm with 42 mm	710 x 910 µm	710 x 910 µm	710 x 910 µm
Light source		Semiconductor laser < 1 mW, 670 nm (red)					
Laser class		Class 2 in accordance with IEC 60825-1: 2014					
Permissible ambient light ^[6]		20,000 lx				7,500 lx	
Supply voltage		24V (11,2 ... 30V) DC, P < 2W					
Power consumption		< 2 W (24 V)					
Signal input		1 x HTL laser on/off; 1 x HTL multifunction input: trigger in, zero setting, teach					
Digital interface		RS422 (16 bit)					
Analog output		4 ... 20 mA (16 bit, freely scalable within the measuring range)					
Digital outputs		1 x error output: npn, pnp, push pull, push-pull negative					
Connection		integrated cable 2 m, open ends, minimum bending radius 30 mm (fixed installation)					
Mounting		Screw connection via two mounting holes					
Temperature range	Storage	-20 ... +70 °C (non-condensing)					
	Operation	0 ... +50 °C (non-condensing)					
Shock (DIN EN 60068-2-27)		15 g / 6 ms in 3 axes, 1000 shocks each					
Vibration (DIN EN 60068-2-6)		20 g / 20 ... 500 Hz in 3 axes, 2 directions and 10 cycles each					
Protection class (DIN EN 60529)		IP67					
Material		Aluminum housing					
Weight		approx. 40 g (without cable), approx. 120 g (incl. cable)					
Control and indicator elements ^[7]		Select button: zero, teach, factory settings; web interface for setup; 2 x color LEDs for power / status					

[1] Factory setting 1 kHz, modifying the factory setting requires the IF2001/USB converter (see accessories)

[2] FSO = Full Scale Output; the specified data apply to white, diffuse reflecting surfaces (Micro-Epsilon reference ceramic for ILD sensors)

[3] Measuring rate 1 kHz, median 9

[4] The specified value is only achieved by mounting on a metallic sensor holder. Good heat dissipation from the sensor to the holder must be ensured.

[5] ±10 %; SMR = Start of measuring range; MMR = Mid of measuring range; EMR = End of measuring range

[6] Illuminant: light bulb

[7] Access to web interface requires connection to PC via IF2001/USB (see accessories)

4 Delivery

4.1 Unpacking, included in delivery

- 1 Sensor ILD1220
 - 1 Setup guide
 - 1 Digital calibration protocol accessible via web interface
 - Accessories (2x M2 screws and 2 washers)
- ▶ Carefully remove the components of the measuring system from the packaging and ensure that the goods are forwarded in such a way that no damage can occur.
- ▶ Check the delivery for completeness and shipping damage immediately after unpacking.
- ▶ If there is damage or parts are missing, immediately contact the manufacturer or supplier.

Optional accessories are listed in the appendix.

Return of packaging

Micro-Epsilon Messtechnik GmbH & Co. KG offers customers the opportunity to return the packaging of products purchased from Micro-Epsilon by prior arrangement so that it can be reused or recycled.

To arrange the return of packaging, for questions about the costs and / or the exact return procedure, please contact us directly at

info@micro-epsilon.de

4.2 Storage

Temperature range:	-20 ... +70 °C
Humidity:	5 ... 95 % RH (non-condensing)

4.3 Structure of the serial number

Sensors in a new design have an extended measuring rate, a higher resolution D/A converter and an improved protection class, [see Chap. 3](#). They can be recognized by the serial number with the following structure:

- 10xxxxxx = ILD1220-10, ILD1220-25, ILD1220-50
- 40xxxxxx = ILD1220-100, ILD1220-200, ILD1220-500

Serial numbers for sensors with the old design can be recognized by the following structure: JJMMxxxx (J = year, M = month)

5 Installation

5.1 Notes on operation

5.1.1 Reflectance of target surface

In principle, the sensor evaluates the diffuse portion of the reflections of the laser light spot.

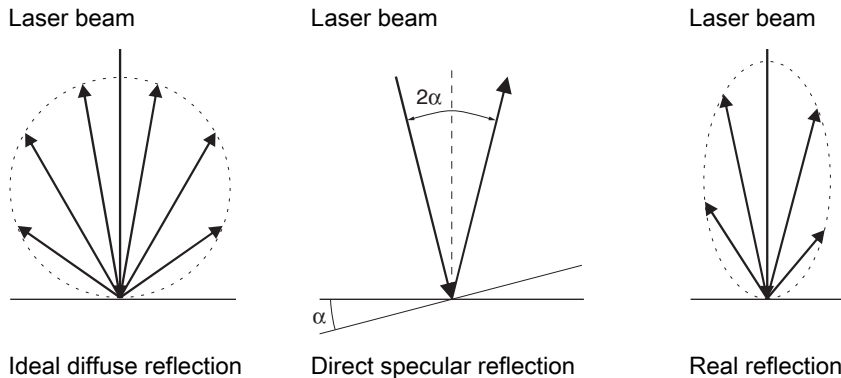

Tab. 5.1: Reflectance of target surface

Any statement about a minimum reflection factor is only possible with reservations, since small diffuse portions can be evaluated even of reflecting surfaces. This is done by determining the intensity of the diffuse reflection from the CMOS signal in real time and then controlling, see Chap. 3.2. However, a longer exposure time may be required for dark or shiny objects, such as black rubber. The maximum exposure time is coupled to the measuring rate and can only be increased by lowering the measuring rate of the sensor.

5.1.2 Error influences

5.1.2.1 Ambient light

The sensors are very good at suppressing ambient light thanks to their built-in optical interference filter. However, ambient light disturbances can occur with shiny measuring objects and at a reduced measuring rate. In these cases it is recommended to provide shielding against ambient light. This applies in particular to measurement work performed in the vicinity of welding devices.

5.1.2.2 Color differences

Because of intensity compensation, color difference of targets affect the measuring result only slightly. However, such color differences are often combined with different penetration depths of the laser light into the material. Different penetration depths then result in apparent changes of the measuring spot size. Therefore color changes in combination with penetration depth changes may lead to measurement uncertainties.

5.1.2.3 Temperature Influences

When the sensor is commissioned a warm-up time of at least 20 minutes is required to achieve uniform temperature distribution in the sensor.

If measurement is performed in the μm accuracy range, the effect of temperature fluctuations on the sensor holder must be considered.

Rapid temperature changes are not detected immediately due to the damping effect of the sensor's heat capacity.

5.1.2.4 Mechanical vibrations

If resolutions in the μm range are to be achieved with the sensor, particular attention must be paid to stable or vibration-damped sensor and target mounting.

5.1.2.5 Movement blur

If the objects being measured are fast moving and the measuring rate is low, it is possible that movement blurs may result. Therefore, always select a high measuring rate for high-speed operations to prevent errors.

5.1.2.6 Surface Roughness

Laser-optical sensors detect the surface using an extremely small laser spot. They also track slight surface unevenness. In contrast, a tactile, mechanical measurement, e.g. with a caliper gauge, covers a much larger area of the measuring object. Surface roughnesses in the order of 5 µm and more lead to an apparent change in distance with traversing measurements.

A suitable averaging number can improve the comparability of the optical and mechanical measurements.

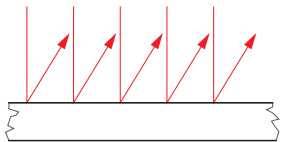

Ceramic reference surface

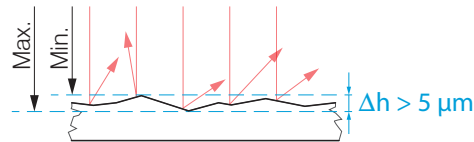

Structured surface

Recommendation for parameter choice:

Select the averaging number so that a comparably large surface area is averaged as for the mechanical measurement.

5.1.2.7 Angular influences

Target tilt angles around both the X and y-axis of less than 5° in the case of diffuse reflection only cause problems with surfaces that produce strong direct reflection.

These influences are particularly important when scanning profiled surfaces. In principle, angular behavior during triangulation is also affected by the reflectivity of the target surface.

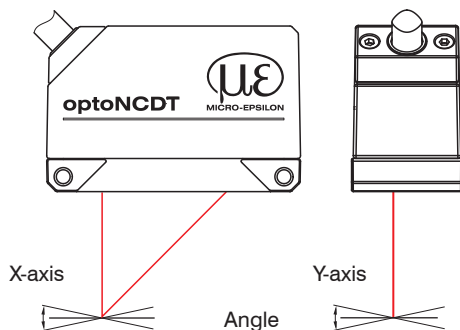

Fig. 5.1: Measurement error caused by tilt angle with diffuse reflection

5.1.3 Optimization of measurement accuracy

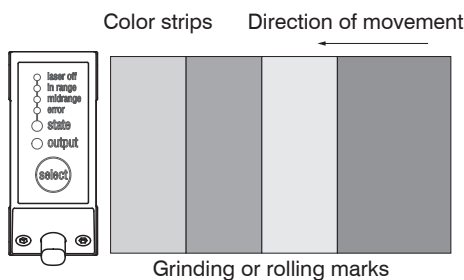
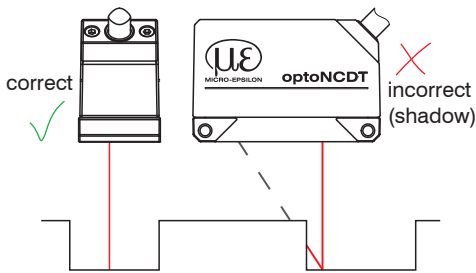

Fig. 5.2: Sensor arrangement for sanded or striped surfaces

In case of rolled or polished metals that are moved past the sensor, the sensor plane must be arranged in the direction of the rolling or grinding marks. The same arrangement must be used for color strips.



In case of bore holes, blind holes and edges in the surface of moving parts, the sensor must be arranged in such a way that the edge does not obscure the laser spot.

Fig. 5.3: Sensor arrangement for holes and edges

5.2 Mechanical fastening, dimensional drawing

The sensor is an optical system that measures in the μm range. If the laser beam does not strike the object surface at a perpendicular angle, measurements might be inaccurate.

i Ensure careful handling during installation and operation.

- ▶ Mount the sensor using 2 M3 screws or the through bores for M2 with the screws from the accessories.

Bolt connection				
Bolt length	Screwing depth	Screw	Washer	Tightening torque per screw
	Minimum	ISO 4762-A2	ISO 7089-A2	$\mu = 0.12$
mm	mm	2 pieces		Nm
20	5.0	M2 x 25	A2.2	0.5

Tab. 5.2: Mounting conditions for bolt connection

Direct fastening				
Screwing depth		Screw	Tightening torque per screw	
Minimum	Maximum	ISO 4762-A2	$\mu = 0.12$	
mm	mm	2 pieces	Nm	
4.8	8.5	M3	1.0	

Tab. 5.3: Mounting conditions for direct fastening

The bearing surfaces surrounding the through-holes (fastening holes) are slightly raised.

5.4 Electrical connections

5.4.1 Connection options for parameterization

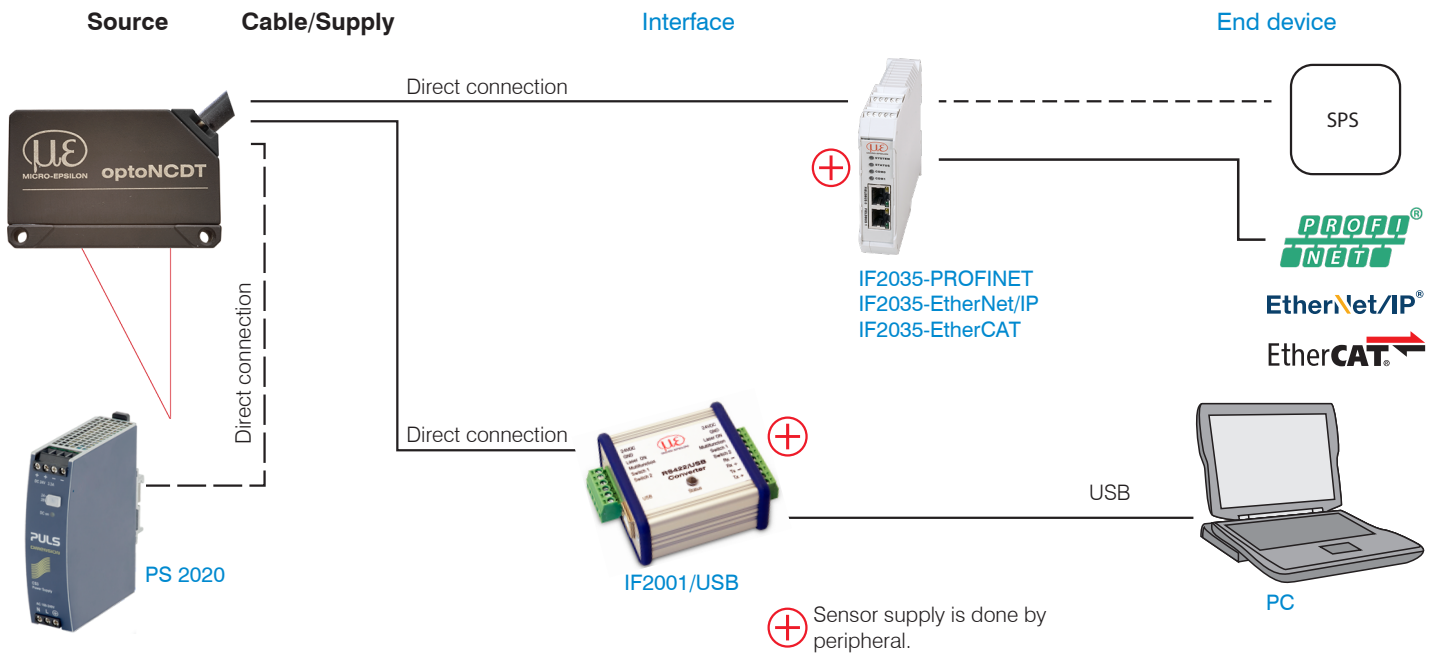

Fig. 5.5: Connection example ILD1220

The periphery devices can be connected to the connection braids, see Fig. 5.5. The IF2001/USB converter also provides the supply voltage (24 VDC) for the sensor. The converter is powered, for example, by the optionally available PS 2020 power supply unit.

Periphery device	Sensor channels	Application/end device
IF2001/USB, RS422-USB converter	a	PC
IF2035-PROFINET / -EtherNet/IP / -EtherCAT	a	PLC
PLC, ILD1220 or similar	---	Function input: Trigger
Button, key, PLC and the like	---	Laser On/Off switching input

Tab. 5.4: Max. sensor channels on the periphery devices

5.4.2 Pin assignment

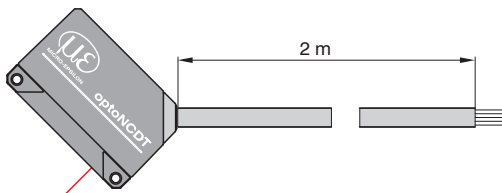

The shielding of the cable is connected to the sensor housing. The sensor cable is not qualified for drag chain use. One end is molded onto the sensor, the other end has braids with ferrules.

Fig. 5.6: ILD1220 with open ends

Signal	Wire color Sensor cable	Explanation	Comments, circuitry
RS422 Rx+	Green	Serial input	Internally terminated with 120 ohms
RS422 Rx-	Yellow		
RS422 Tx+	Gray	Serial output	Terminate with 120 ohms at the receiver
RS422 Tx-	Pink		
V ₊	Red	Operating voltage	11.2 ... 30 VDC, typ. 24 VDC, P < 2 W

Signal	Wire color Sensor cable	Explanation	Comments, circuitry
Laser on/off	Black	Switching input	Laser active when the input is connected to GND
Function input	Violet		Trigger, zero, teaching
Error	Brown	Digital outputs	$I_{max} = 100 \text{ mA}$, $U_{max} = 30 \text{ VDC}$ Switching behavior programmable: (NPN, PNP, push-pull, push-pull negated)
I_{OUT}	White	4 ... 20 mA	$R_{load} = 250 \text{ ohm}$ results in $U_{OUT} 1 \dots 5 \text{ V}$ for $V_+ > 11.2 \text{ V}$ $R_{load} = 500 \text{ ohm}$ results in $U_{OUT} 2 \dots 10 \text{ V}$ for $V_+ > 17 \text{ V}$
GND	Blue	Reference ground	Supply and signal ground
Connector housing	Shield	Sensor housing	Connect to potential equalization

5.4.3 Supply voltage

Nominal value: 24 VDC (11.2 ... 30 V, $P < 2 \text{ W}$).

- ▶ Only turn on the power supply after wiring has been completed.
- ▶ Connect the "red" and "blue" wires on the sensor to a 24 V power supply.

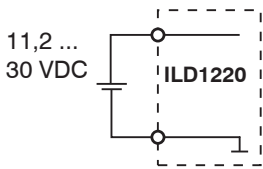

Wire color	Power supply
Red	V_+
Blue	Ground

Tab. 5.5: Supply voltage connection

Voltage supply only for measuring devices, not to be used for drives or similar sources of impulse interference at the same time. Micro-Epsilon recommends using an optional available power supply unit PS2020 for the sensor.

5.4.4 Turning on the Laser

The measuring laser on the sensor is switched on via an HTL switching input. This is advantageous when it comes to switching the sensor off for maintenance work or the like. Both a switching transistor with an open collector (for example in an optocoupler) and a relay contact are suitable for switching.

i The laser remains switched off as long as the black and blue wires are not electrically connected.

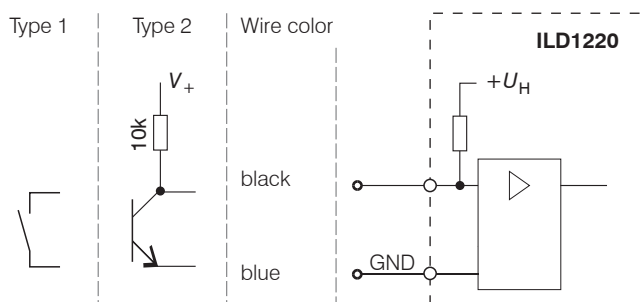

Fig. 5.7: Basic circuit for switching on the laser

An external resistor is not required for current limitation. For permanent "Laser on", the "Black" and "Blue" wires must be connected.

Response time: The sensor needs approx. 1 ms until correct measurement data is sent after the laser is switched on again.

5.4.5 RS422 connection with USB converter IF2001/USB

For the connection between sensor and PC, the lines must be crossed.

i Only disconnect or connect the sensor to the USB converter when the power is switched off.

Sensor		Terminal device (Converter) type IF2001/USB from Micro-Epsilon
Signal	Sensor cable	
GND	Blue	GND
Tx -	Pink	Rx -
Tx +	Gray	Rx +
Rx -	Yellow	Tx -
Rx +	Green	Tx +

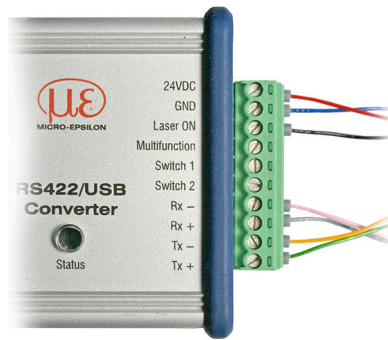

Symmetric differential signals acc. to EIA-422, not electrically isolated from supply voltage. Use a shielded cable with twisted wires.

Tab. 5.6: Pin assignment IF2001/USB

5.4.6 Analog output

The sensor provides a current output of 4 ... 20 mA.

i The current output must not be used continuously in short-circuit operation without a load. Continuous short-circuit operation leads to thermal overloading and thus causes the output to switch off automatically.

► Connect the "white" and "blue" wires on the sensor to a measuring device.

Sensor	
Signal	Sensor cable
I_{OUT}	White
GND	Blue

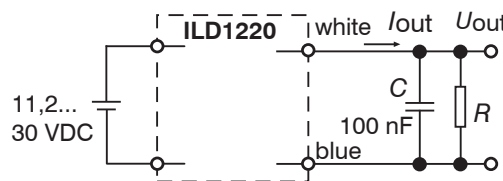

With the adjacent circuit, you receive an analog voltage at the output in the range from 1 ... 5 V.
 $R = 250 \text{ ohm}$:
 $U_{OUT} 1 \dots 5 \text{ V for } V_+ > 11.2 \text{ V}$
 $R = 500 \text{ ohm}$:
 $U_{OUT} 2 \dots 10 \text{ V for } V_+ > 17 \text{ V}$

Tab. 5.7: Wiring for voltage output

5.4.7 Multifunction input

The multifunction input enables the triggering, zeroing and teaching functions. The function depends on the programming of the input and on the timing of the input signal.

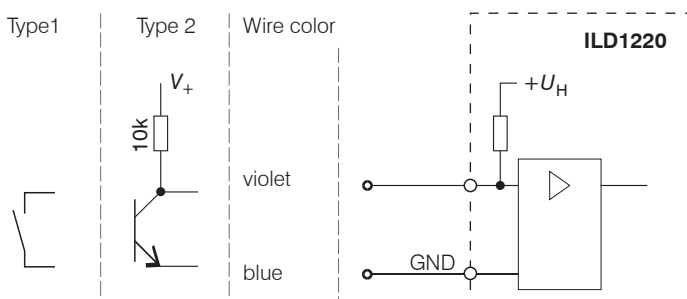

Input is not electrically separated.
 24V logic (HTL):
 Low level $\leq 2 \text{ V}$
 High level $\geq 8 \text{ V}$ (max 30 V)
 Internal pull-up resistor, an open input is detected as High.
 Connect the input to GND to trigger the function.

Fig. 5.8: Basic circuit for multi-function input

5.4.8 Switching output

The switching behavior (NPN, PNP, push-pull, push-pull negated) of the switching output (error) depends on the programming.

The NPN output is suitable, for example, for adaptation to TTL logic with an auxiliary voltage $U_H = +5 \text{ V}$. The switching output is protected against reverse polarity, overload ($< 100 \text{ mA}$) and excessive temperature.

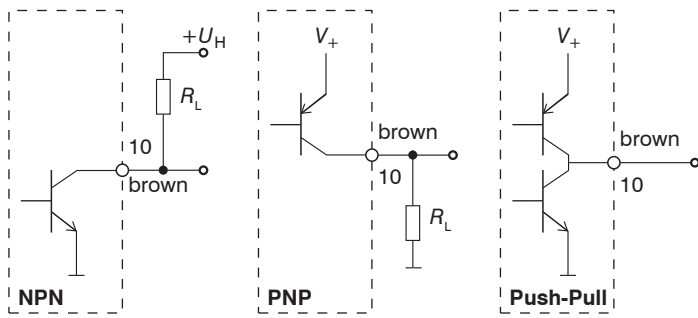

Output is not electrically separated.
 24V logic (HTL),
 $I_{max} = 100 \text{ mA}$,
 $U_{Hmax} = 30 \text{ V}$ saturation voltage at
 $I_{max} = 100 \text{ mA}$:
 Low < 2.5 V (output - GND),
 High < 2.5 V (output - V_+)

Fig. 5.9: Basic circuit for switching output

Switching behavior		
Name	Output active (error)	Output passive (no error)
NPN (Low side)	GND	approx. + U_H
PNP (High side)	V_+	approx. GND
Push-pull	V_+	GND
Push-pull, negated	GND	V_+

Tab. 5.8: Switching output behavior

Activates the switching output when there is no measuring object, when the object is too close/far or when no valid measurement value can be determined.

5.4.9 Sensor cable

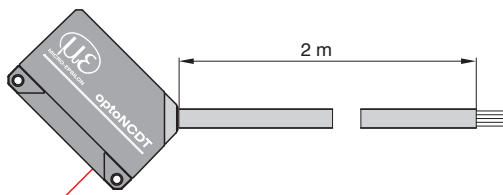

Fig. 5.10: ILD1220 with open ends

- ▶ Do not bend the sensor cable more tightly than 30 mm (immovably routed) or 60 mm (movable).

i The permanently connected sensor cables are not suitable for drag chains.

i Unused open cable ends must be insulated or bluntly cut to protect against short circuits or sensor malfunctions.

- ▶ Avoid excessive pull on the cables. If a cable of over 5 m in length is used and it hangs vertically without being secured, make sure that some form of strain relief is provided close to the connector.
- ▶ Connect the cable shield to the potential equalization (PE, protective earth conductor) on the evaluator (control cabinet, PC housing) and avoid ground loops.
- ▶ Never lay signal lines next to or together with power cables or pulse-loaded cables (e.g., for drives or solenoid valves) in a single bundle or duct. Always use separate ducts.

Recommended strand cross-section for self-made connection cables: $\geq 0.14 \text{ mm}^2$.

6 Operation

6.1 Getting Ready for Operation

- ▶ Mount the optoNCDT 1220 according to the installation instructions, see Chap. 5.
- ▶ Connect the sensor to downstream display or monitoring units and the power supply.

The laser diode in the sensor is only activated when the black wire is connected to the blue wire at the Laser on/off pin, see Chap. 5.4.4.

After switching on the supply voltage, the sensor runs through an initialization sequence. This is indicated by the momentary activation of all LEDs. After initialization has been completed, the sensor sends a "->" via the RS422 interface. Initialization takes a maximum of 10 seconds.

During this time, only the `Reset` or `Bootloader` command is executed via the `Select` button.

The sensor requires a warm-up time of typically 20 minutes for reproducible measurements.

If the `Output` LED is off, no power is being supplied.

If the `State` LED is off, the laser light source is switched off.

6.2 Parameterization via web interface

6.2.1 Requirements

A web server is implemented in the sensor; the web interface contains, among other things, the current settings of the sensor and the peripherals. Operation is only possible as long as there is an RS422 connection to the sensor. The sensor is connected to a PC/notebook via an RS422 converter, the supply voltage is applied.

`sensorTOOL` by Micro-Epsilon is software that you can use to apply settings to the sensor and to view and document measurement data.

You can find these online at <https://www.micro-epsilon.de/fileadmin/download/software/sensorTOOL.exe>.

You need a web browser compatible with HTML5 on a PC/notebook.

- ▶ Click on the `Sensor` button.

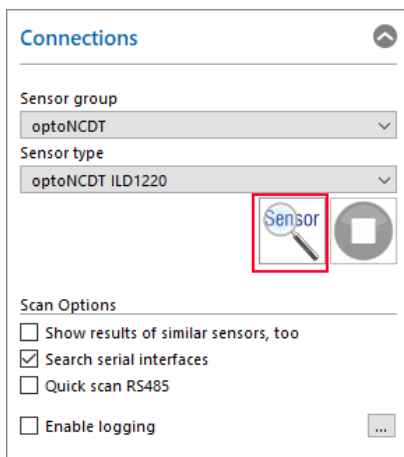

The program searches for connected sensors of the ILD1220 series on the available interfaces.

- ▶ Select a desired sensor. Click the `Open Website` button.

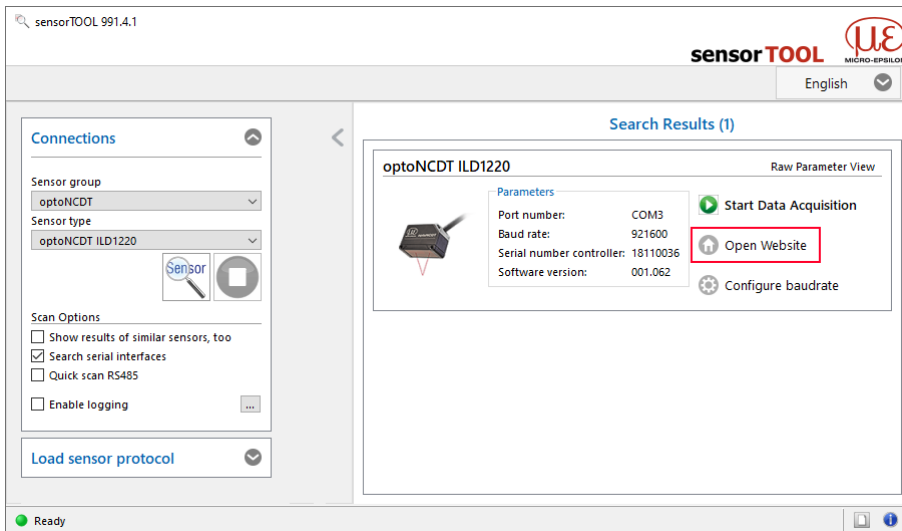

Fig. 6.1: Utility for sensor search and start web interface

6.2.2 Access via web interface

- ▶ Start the sensor's web interface, see Chap. 6.2.1.

Interactive web pages for configuring the sensor now appear in the web browser.

The appearance of the web sites can change depending on the functions. Each page contains parameter descriptions and tips on completing the web page.

The sensor is active and supplies measured values at a low output rate.

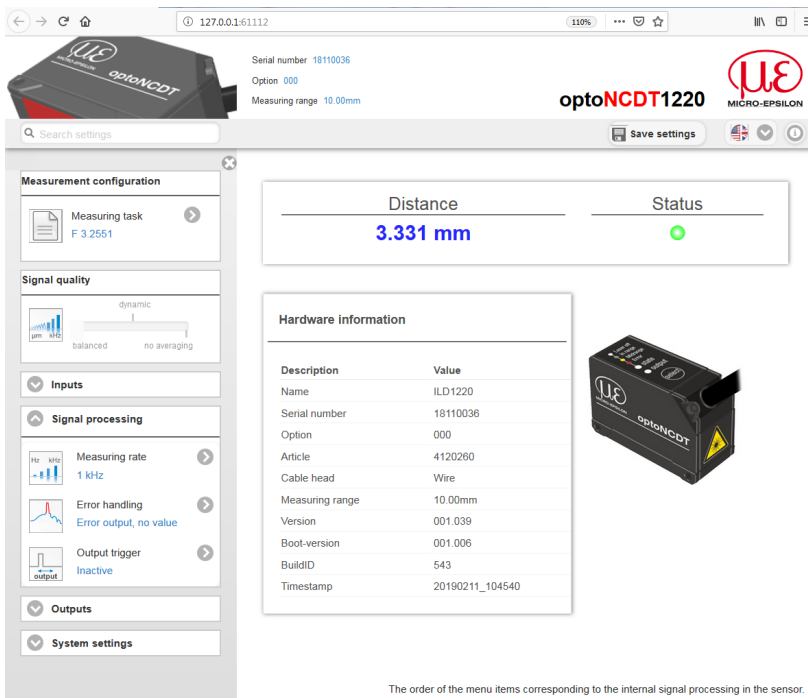
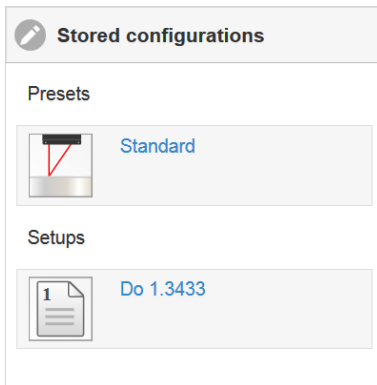

Fig. 6.2: First interactive web page after calling up the web interface

Click on the ► button in the Measurement configuration area to switch between the saved configurations. In the delivery state, the Standard preset is set. Individual user programs can be permanently stored in a so-called setup.



Standard preset

The measurement configuration is factory-set for ceramics and metals.

Setup(s)

Individual measurement settings can be saved in a setup and activated in the sensor at any time.

If you are working with the `Standard` preset, you can change the settings using the `Signal quality` slider.

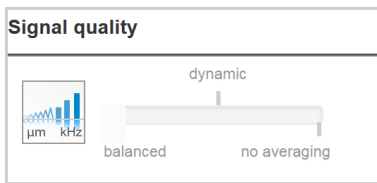

Averaging

- Balanced
- Moving, 64 values
- Dynamic
- Median, 9 values
- without averaging

Description

In the `Signal quality` area, you can switch between three default settings (balanced, dynamic and without averaging) with a mouse click.

The `System` settings area shows the current settings for e.g. unit and access authorization in blue.

i After programming, save all settings permanently to a parameter set so that they will be available again the next time you switch on the sensor. To do this, use the `Save settings` button.

6.2.3 Calibration protocol

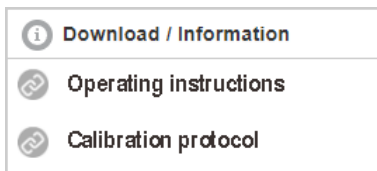

In the menu item `Info`, you will find the calibration protocol for download under `Download / Information`.

6.3 Programming via ASCII Commands

As an additional feature, you can program the sensor via an ASCII interface, physically RS422. For this purpose, the sensor must be connected to a serial RS422 interface using a suitable interface converter, see [Chap. 14](#), to a PC/PLC.

i Observe the correct RS422 basic setting in the programs used.

After the connection has been established, you can transmit commands listed in the Appendix, see [Chap. 16](#), to the sensor using a terminal program.

6.4 Time response, measurement value flow

The sensor requires 3 cycles to measure and process without triggering:

The cycle time is 1000 μ s at a measuring rate of 1 kHz. The measured value N is available at the output after three cycles. The delay time between detection and start of output is therefore 3000 μ s. As the cycles are processed in parallel, the next measured value (N+1) is output after a further 1000 μ s.

7 Set sensor parameters, web interface

7.1 Preliminary remarks concerning the setting options

You can parameterize the sensor in various ways:

- Using the web browser and sensor web interface
- With ASCII command set and terminal program via RS422

i If you do not permanently save the programming in the sensor, the settings will be lost after the sensor is switched off.

Legend of the menu structure:

 Fields with gray background require a selection.

Value

Fields with dark border require entry of a value.

7.2 Overview of parameters

You can set or change the following parameters in the optoNCDT 1220, see [Settings tab](#).

Inputs	Multi-function input, button function
Signal processing	Measuring rate, error handling, triggering (data output)
Outputs	RS422, analog output, switching output
System Settings	Unit on website, key lock, load & save, import & export, access authorization, reset sensor (factory settings)

7.3 Inputs

7.3.1 Overview of functions

- ▶ Switch to the [Inputs](#) menu.

Multifunction input	<i>Zero</i>	<i>High / Low</i>	<i>Defines the function of the switching input. The trigger influences the output of a measured value. Zeroing sets the output value to half the analog output value. Teaching scales the analog output. HTL is defined as the active input level.</i>
	<i>Trigger In</i>	<i>High / Low</i>	
	<i>Teaching</i>		
	<i>Disabled</i>		
Key function	<i>Zero</i>		<i>Defines the function of the sensor button. Inactive means key lock.</i>
	<i>Teaching</i>		
	<i>Disabled</i>		

7.3.2 Zeroing

The [Zeroing](#) function sets the output value to half the analog output value or to zero (digital value in the web interface). This shifts the output range. This feature can be useful, for example, when several sensors carry out measurements simultaneously in thickness and planarity measurements.

Zero setting is used to compensate for mechanical tolerances in the measurement setup of the sensors or for relative measurements. When setting a zero, the sensor characteristic is moved in parallel.

Zeroing procedure:

- ▶ Place measuring object and sensor into their desired positions to one another.
- ▶ Trigger the zero setting function via the hardware input or the button on the sensor.

After zeroing, the sensor provides new measurement values relative to the measured value during zeroing.

- i Zeroing requires a measuring object in the measuring range.
Zeroing affects the analog and digital outputs.

7.3.2.1 Zeroing with the Select button

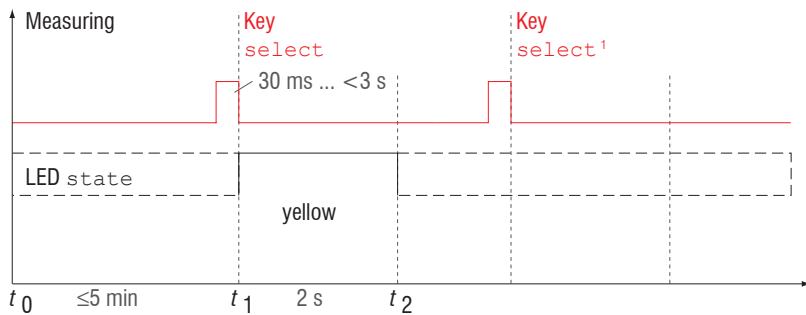

Fig. 7.1: Flowchart for zeroing, `keySelect`

- i The key `Select`^[8] is locked after 5 minutes according to the factory setting. You can deactivate the key lock via the web interface, for example, see Chap. 7.6.3.

The `State` LED lights up green, red, yellow, depending on the position of the measuring object. If the `State` LED is red, zeroing is not performed, flashing frequency 8 Hz for 2 s.

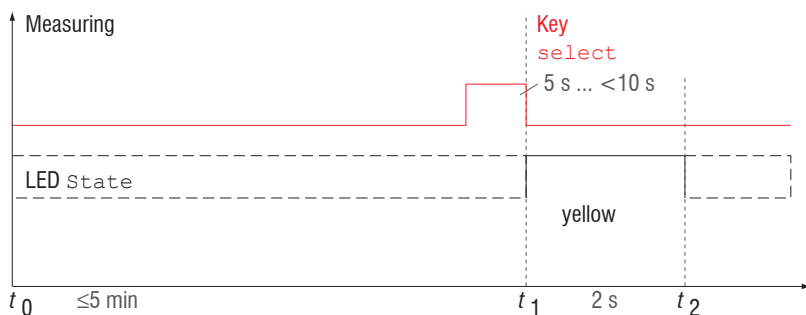

Fig. 7.2: Flowchart for resetting zeroing

The `Zero` setting function can be used several times in succession. A pause of 1 s is required between repeating the function `Zero` setting. The zero setting function can also be combined with the multifunction input.

7.3.2.2 Zeroing via hardware input

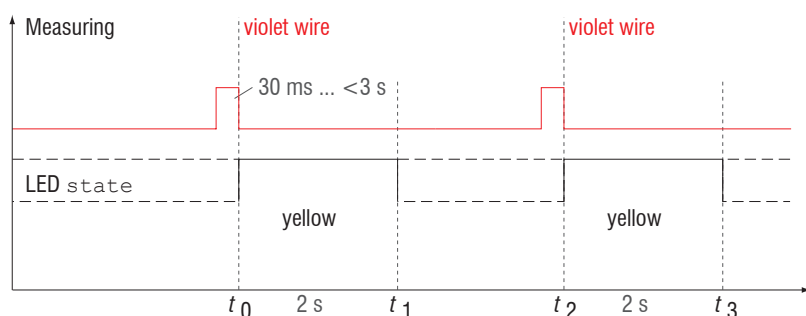

Fig. 7.3: Flowchart for zeroing (hardware input)

- i A pulse is possible at the function input of the violet wire of the sensor cable. Details about the hardware input can be found in the electrical connections, see Chap. 5.4.7.

The `LED State` lights up green, red, yellow, depending on the position of the measuring object. If the `State` LED is red, zeroing is not performed, flashing frequency 8 Hz for 2 s.

[8] The `Select` key has no effect because the key lock is active.

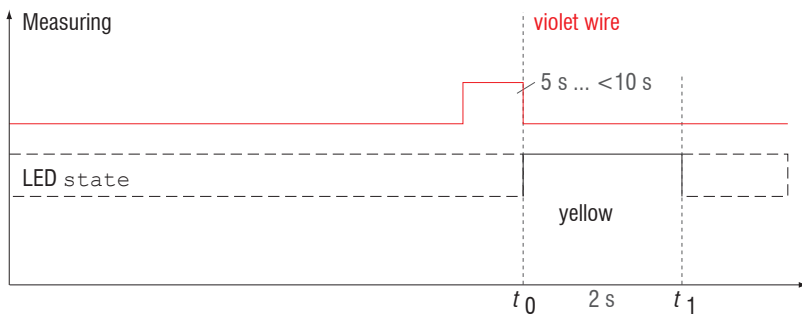

Fig. 7.4: Flowchart for undoing zeroing

The `Zero` setting function can be used several times in succession. A pause of 1 s is required between repeating the function `Zero` setting. The `Zero` setting function can also be combined with the `Select` button.

7.4 Signal Processing

7.4.1 Preliminary remark

- Switch to the `Signal processing` menu in the vertical navigation bar.

Information on the selected setting is shown on the right-hand side of the display.

All settings are applied immediately.

7.4.2 Measuring rate

The measuring rate indicates the number of measurements per second.

- Select the required measuring rate.

Measuring rate	250 Hz / 500 Hz / 1 kHz / 2 kHz	Use a high measuring rate for bright and mat measuring objects. Use a low measuring rate for dark or shiny measuring objects (e.g. black painted surfaces) to improve the measurement result.
----------------	---------------------------------	---

At a maximum measuring rate of 1 kHz, the CMOS element is exposed 1000 times per second. The lower the measuring rate, the longer the maximum exposure time.

The measuring rate is set to 1 kHz at the factory.

7.4.3 Error Handling

The error handling function regulates the behavior of the analog output and RS422 interface in the event of an error.

Error Handling	<i>Error output, no measured value</i>	<i>The analog output supplies 3 mA instead of the measured value. The RS422 interface outputs an error value.</i>
	<i>Hold last value infinitely</i>	<i>The analog output and RS422 interface remain on the last valid value.</i>
	<i>Hold last value</i>	1 ... 1024

If no valid measured value can be determined, an error is output. Alternatively, if this interferes with further processing, the last valid value can be held, i.e. output repeatedly, for a certain amount of time. After the selected number of cycles have elapsed, an error value is output.

7.4.4 Triggering

7.4.4.1 General

An external electric trigger signal or a command control the output of measured values. Both analog and digital outputs are affected by this. The measured value at the time of the trigger event is output with a delay, see Chap. 6.3.

- Triggering has no effect on the time response, so that there are always 3 cycles + 1 cycle (jitter) between the trigger event (level change) and the start of the output.
- The multifunction input is used as the external trigger input, [see Chap. 5.4.7](#).
- Factory setting: no triggering, the sensor starts data transmission immediately after being switched on.
- The pulse duration of the "Trigger in" signal is at least 50 μ s.

<i>Output Trigger</i>	<i>Level</i>			<i>Measurement values are output continuously as long as the selected level applies. Level selection, see Chap. 7.3. The pulse duration must be at least as long as one cycle. The subsequent pause must be at least as long as one cycle.</i>
	<i>Edge</i>	<i>infinite</i>		<i>Edge selection, see Chap. 7.3. "0" End trigger, "1 ... 16382" values per trigger, "16383" End lot trigger</i>
		<i>manual</i>	<i>Number</i>	
<i>Disabled</i>				<i>No triggering</i>

The following applies to triggering:

$$f_T < f_M \quad f_T \quad \text{Trigger frequency}$$

$$f_M \quad \text{Measuring rate}$$

The following are used as triggering conditions:

Level triggering with high level / low level.

Continuous measured value output for as long as the selected level is active. Afterwards, the data acquisition/output stops.

The pulse duration must be at least as long as one cycle. The subsequent pause must also be at least as long as one cycle.

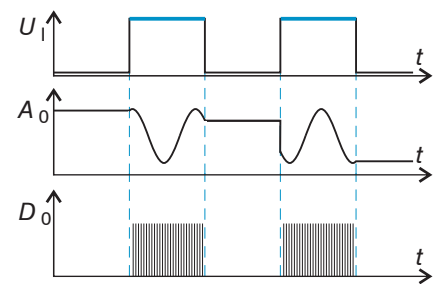

Fig. 7.5: Trigger level High (top) with analog output A_0 and digital output signal D_0 (bottom)

Edge triggering with rising or falling edge.

Starts measured value output as soon as the selected edge is present at the trigger input. The sensor outputs the specified number of measured values when the triggering condition is met. Value range from 1 ... 16383. After completion of data output the analog output remains at the last value (Sample & Hold).

The pulse duration must be at least 50 μ s.

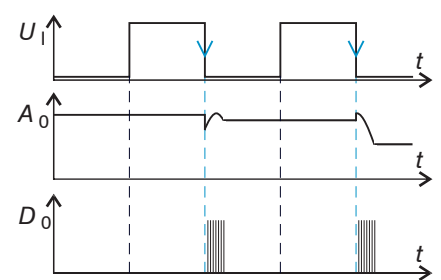

Fig. 7.6: Trigger edge HL (top) with analog output A_0 and digital output signal D_0 (bottom)

7.4.4.2 Triggering the output of measurement values

The measured values are computed continuously and independently of the trigger event. A trigger event merely triggers output of the values via a digital or analog interface. Therefore, any values measured immediately before the trigger event are included in calculating mean values (averages).

7.5 Outputs

7.5.1 Overview

RS422	Baud rate	9.6 / 19.2 / 56.0 / 115.2 / 230.4 ... / 1000 kBps		Transmission speed, binary data format
	Output data	Distance / measurement counter		The data intended for transmission must be activated with the checkbox.
Analog Output	Standard scaling			Measuring range start 4 mA, at measuring range end 20 mA
	Two-point scaling	Start of range	Value	In every case, 2 points are taught which characterize the start and the end of the new measuring range. Two-point scaling allows the output signal to be reversed.
		End of range	Value	
Switching output	Disabled			
	Measuring range	NPN / PNP / PushPull / PushPullNeg		The switching output switches when the received signal is not (completely) within the evaluation range (ROI).
	Analog range	NPN / PNP / PushPull / PushPullNeg		The switching output switches when the scaled analog range is exceeded.
	limit monitoring	NPN / PNP / PushPull / PushPullNeg		The switching output switches when the limit value is exceeded.
		limit monitoring mm/inch	Value	
		Hysteresis mm/inch	Value	Value by which the measured value must fall short of the limit value to deactivate the switching output.
Minimum holding time		Value	Specification of the minimum time in 1 ... 1000 ms for which the switching output should remain active if the limit value is exceeded. The time period begins when the limit value is exceeded.	
Data Output	Analog / RS422			Selection of the interface used. With the RS422 interface, the signal is not displayed in the web interface. With analog output, the signal can still be displayed in the web interface.

7.5.2 Digital output, RS422

7.5.2.1 Values, Ranges

The digital measurements are output at the sensor as unsigned digital values (raw values). 16 or 18 bits per value are transmitted. Below you will find a compilation of the output values and the conversion of the digital value.

Value	Length	Variables	Value range	Formula
Distance	16 bits	$x =$ digital value	[0; <643] SMR reserve [643; 64887] Measuring range [>64887; 65520] EMR reserve	$d \text{ [mm]} = \frac{1}{100} \left(\frac{102}{65520} x - 1 \right) * MR \text{ [mm]}$
		$MR =$ measuring range [mm]	{10/25/50/100/200/500}	
		$d =$ distance [mm]	[-0.01 MR ; 1.01 MR]	
Distance (with mastering)	18 bits	$x =$ Digital value	[0; 229320]	$d \text{ [mm]} = \frac{1}{100} \left(\frac{102}{65520} x - 51 \right) * MR \text{ [mm]}$
		$MR =$ Measuring range [mm]	{10/25/50/100/200/500}	
		$MP =$ Master position [mm]	[0; MR]	
		$MV =$ Master value [mm]	[0; $2MR$]	
		$d =$ distance [mm]		
		$MV < MP - 0.5MR.$	[-0.5 $MR + MV$; $MR - MP + MV$]	
$MV \geq MP - 0.5MR.$	[- $MP + MV$; $MR - MP + MV$]			
Measured Value Counter	18 bits	$x =$ Digital value	[0; 262143]	

State information transferred in the distance value

Distance value	Description	Distance value	Description
262075	Too much data for selected baud rate	262080	Measurement value cannot be evaluated
262076	No peak is present	262081	Peak is too wide
262077	Peak is before the measuring range (MB)	262082	Laser is switched off
262078	Peak is after the measuring range (MR)		

7.5.2.2 Behavior of the Digital Output

Measured values based on the zero setting or master function are coded with 18 bits. Master value range: 0 ... 2x measuring range. The examples show the behavior of the digital value with an ILD1220-50, measuring range 50 mm.

Target at 16 % measuring range

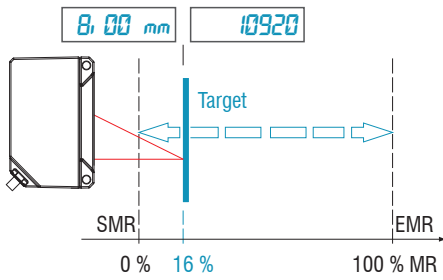

► Zero setting (master value = 0 mm)

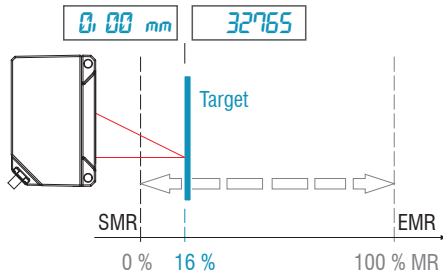

Target at 60 % measuring range

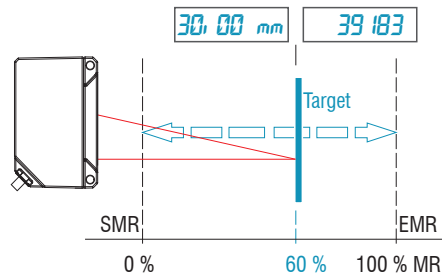

► Zero setting (master value = 0 mm)

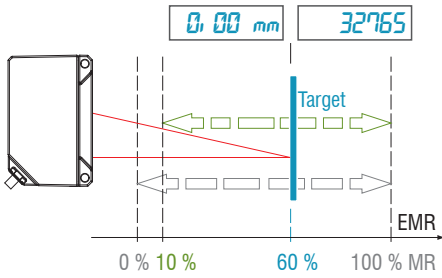

Target at 60 % measuring range

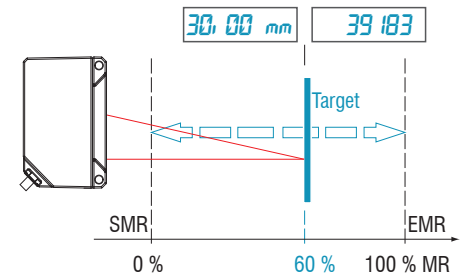

► Set master value 10 mm

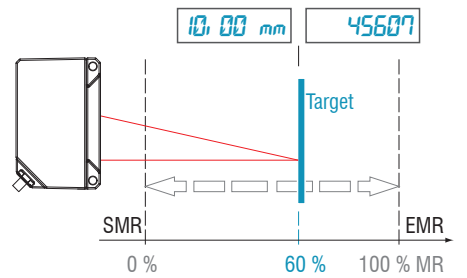

Digital minimum reached at 10 % MR

The mastering function is possible with the ASCII command MASTERMV, see Chap. 16.3.8.3.

► Set target at 80 % measuring range (40 mm), set master value 100 mm

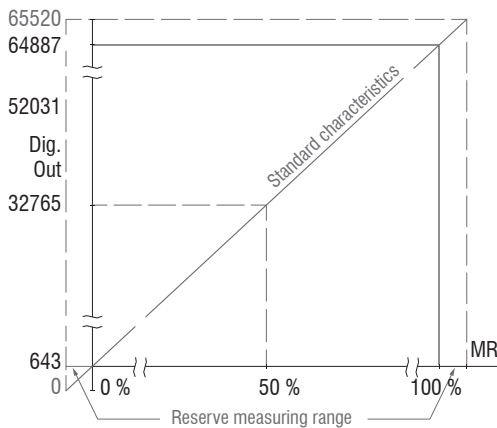
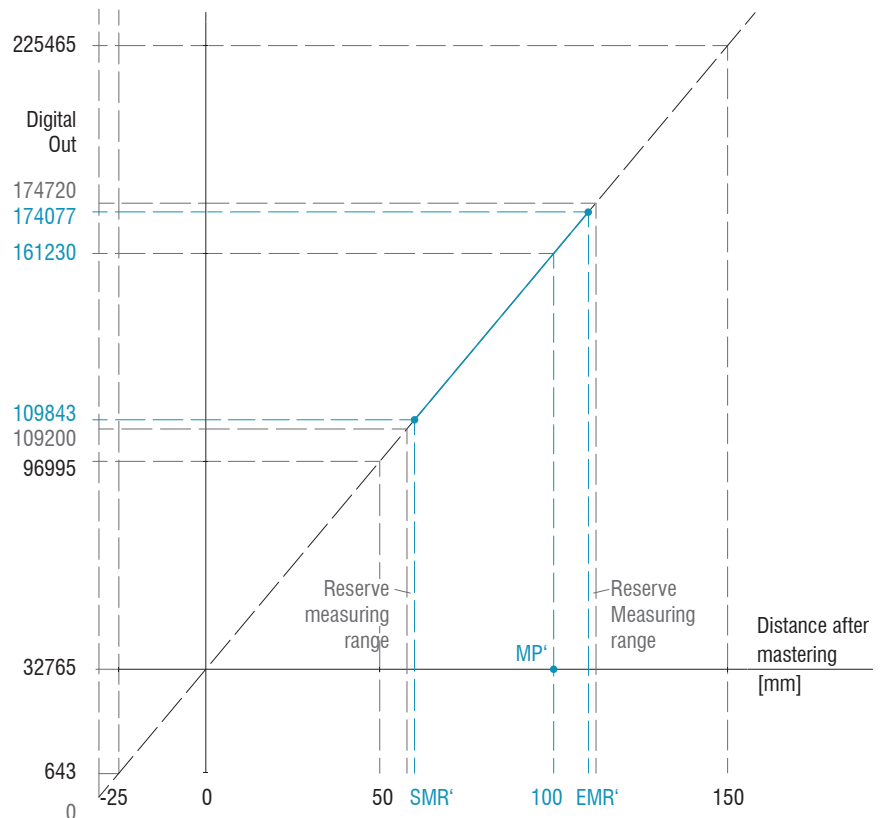

Fig. 7.7: Digital values without zero setting or mastering

Fig. 7.8: Digital values of an ILD1220-50 after mastering with 100 mm master value

7.5.3 Analog output

7.5.3.1 Output scaling

- Max. output range: 4 mA ... 20 mA
- Output amplification ΔI_{OUT} : 16 mA = 100 % MR
- Error value: 3.0 mA ($\pm 10 \mu\text{A}$)

Teaching scales the analog output. This allows you to optimize the resolution for the analog output. The behavior of the current and switching output changes. In every case, 2 points are taught which characterize the start and the end of the new measuring range. Teaching is via the built-in `Select` button, the `Multifunction` input or via the web interface.

- i In conjunction with a user-defined output characteristic curve, you can use the switching output, see [Chap. 5.4.8](#), as a sliding limit switch.

The measuring object positions for `Teach 1` (start of range) and `Teach 2` (end of range) must be different.

The teaching process requires a valid measurement signal. In case of

- No object,
- object cannot be evaluated,
- too close to the sensor - outside SMR or
- too far from the sensor - outside EMR

the teaching process is aborted.

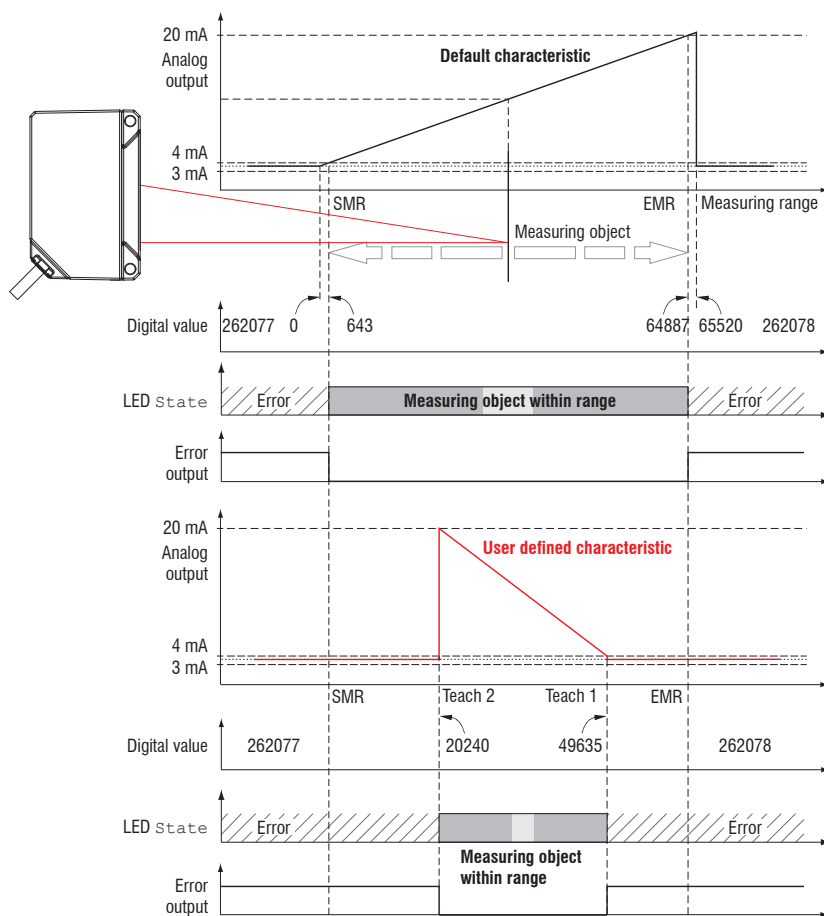

Fig. 7.9: Standard characteristic (black), reversed, user-specific characteristic (red)

7.5.3.2 Output scaling with the Select button

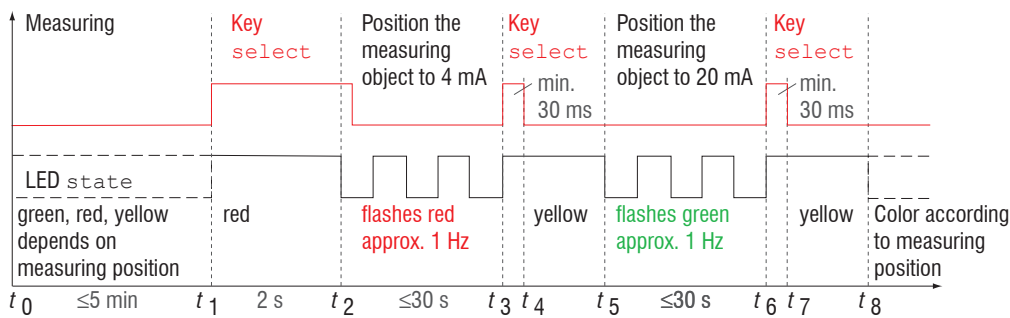

Fig. 7.10: Flowchart for output scaling

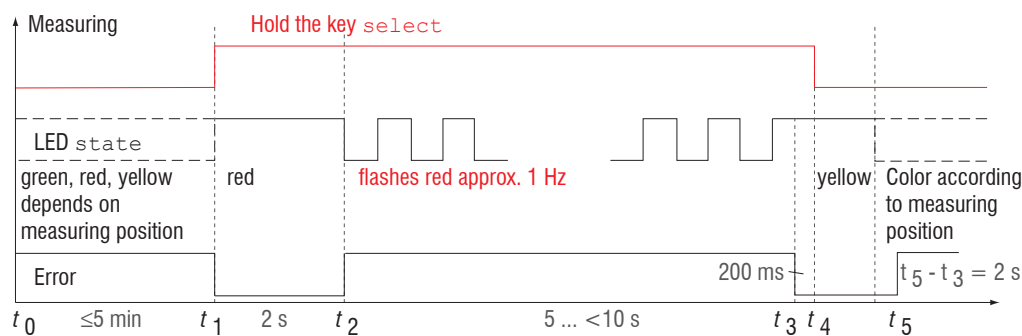

Fig. 7.11: Flowchart for resetting the output scaling

When resetting the output scaling, the State LED displays an error when the Select button is pressed for longer than 10 s or not within the frame. The State LED then flashes red at 8 Hz for two seconds.

7.5.3.3 Output Scaling via Hardware Input

Scaling of the analog output is possible via a pulse at the function input, the purple wire on the sensor cable.

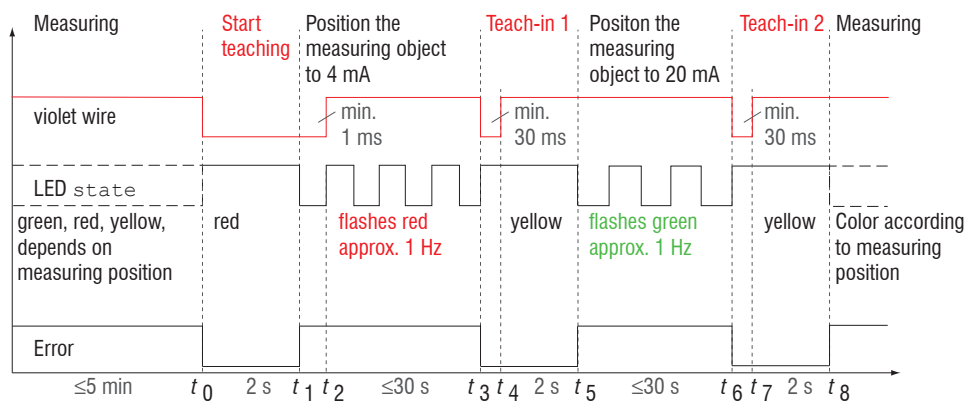

Fig. 7.12: Flowchart for output scaling

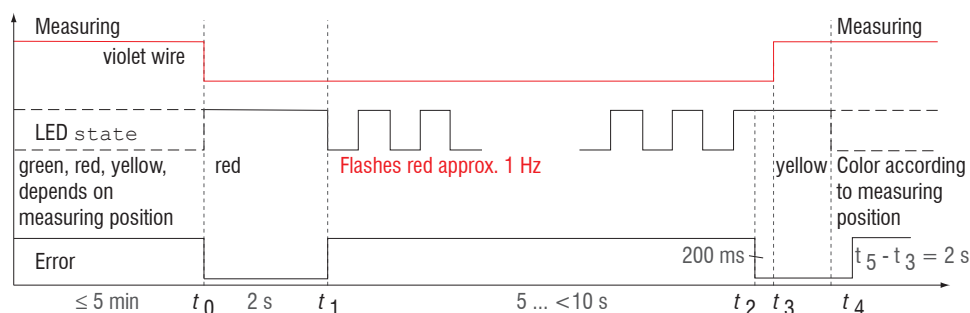

Fig. 7.13: Flowchart for resetting the output scaling

7.5.3.4 Calculation of measured value from analog current

Current output (without zeroing, without teaching)		
Variables	Value range	Formula
I_{OUT} = Current [mA]	[3.8; <4] SMR reserve [4; 20] Measuring range [>20; 20.2] EMR reserve	$d \text{ [mm]} = \frac{(I_{OUT} \text{ [mA]} - 4)}{16} * MR \text{ [mm]}$
MR = Measuring range [mm]	{10/25/50/100/200/500}	
d = Distance [mm]	[-0.01MB; 1.01MB]	

Current output (with zero setting), reference value mid of measuring range		
Variables	Value range	Formula
I_{OUT} = Current [mA]	[3.8; <4] SMR reserve [4; 20] Measuring range [>20; 20.2] EMR reserve	$d \text{ [mm]} = \frac{(I_{OUT} \text{ [mA]} - 12)}{16} * MR \text{ [mm]}$
MR = Measuring range [mm]	{10/25/50/100/200/500}	
ZP = Zero setting position [mm]	[0; MR]	
d = Distance [mm]	for $MP \leq 0.5 MR$: [-MP; 0.5 MR] for $MP > 0.5 MR$: [-0.5 MR; MR - MP]	

Current output (with teaching)		
Variables	Value range	Formula
I_{OUT} = Current [mA]	[3.8; <4] SMR reserve [4; 20] Measuring range [>20; 20.2] EMR reserve	$d \text{ [mm]} = \frac{(I_{OUT} \text{ [mA]} - 4)}{16} * n \text{ [mm]} - m \text{ [mm]} $
MR = Measuring range [mm]	{10/25/50/100/200/500}	
m, n = Teach range [mm]	[0; MR]	
d = Distance [mm]	[m; n]	

Current output (with zero setting and teaching)		
Variables	Value range	Formula
I_{OUT} = Current [mA]	[3.8; <4] SMR reserve [4; 20] Measuring range [>20; 20.2] EMR reserve	$d \text{ [mm]} = \frac{(I_{OUT} \text{ [mA]} - 12)}{16} * n \text{ [mm]} - m \text{ [mm]} $
MR = Measuring range [mm]	{10/25/50/100/200/500}	
ZP = Zero setting position [mm]	[0; MR]	
m, n = Distance [mm] ^[9]	[0; MR]	
d = Distance [mm]	[m; n]	

7.5.3.5 Behavior Distance Value and Analog Output

The zero setting function sets the analog output to half of the output range, i.e. 12 mA, regardless of the zero setting position. The examples show the behavior of the current output and the distance value using the example of an ILD1220-50, measuring range 50 mm.

[9] If one of the teach points (m, n) is outside the measuring range (MR) due to zeroing, the sensor outputs an error message.

Target at 16 % measuring range

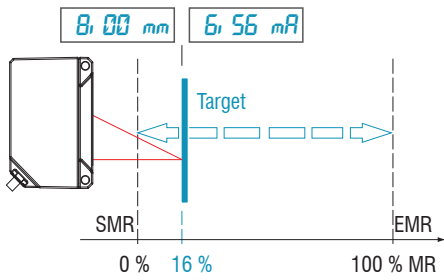

Target at 60 % measuring range

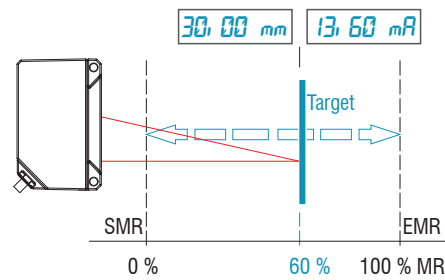

► Zero setting

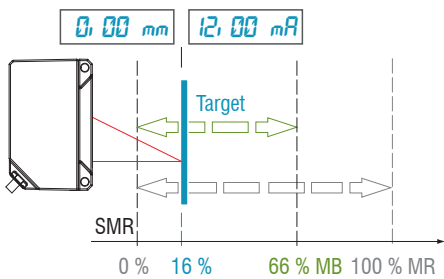

Analog maximum reached at 66 % MR

► Zero setting

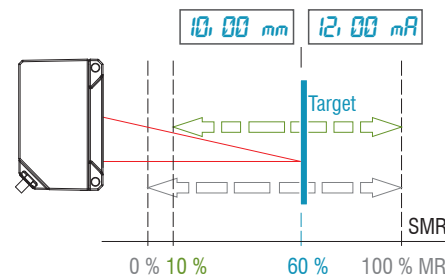

Analog minimum reached at 10 % MR

MR = Measuring range, SMR = Start of measuring range, EMR = End of measuring range

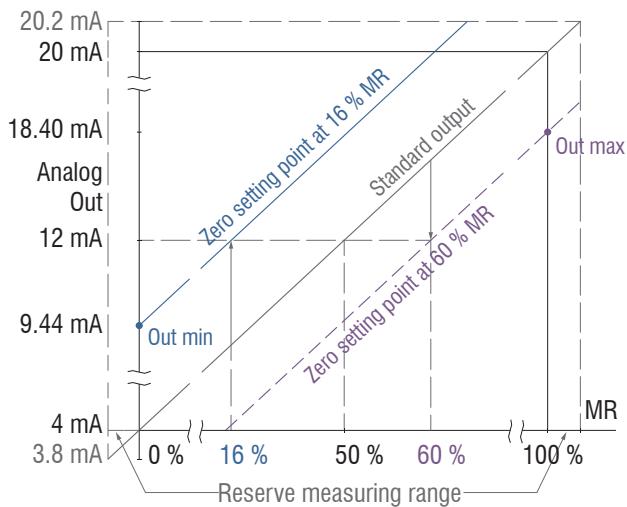

Fig. 7.14: Analog output signal with zero setting, measuring range 50 mm

Zero set point	Out min	Out max
16 % (8 mm)	9.44 mA (-8 mm)	20.0 mA (33 mm)
60 % (30 mm)	4.00 mA (-15 mm)	18.40 mA (30 mm)

7.5.3.6 Analog output, zeroing and teaching

Please observe the following order:

1. Zero setting, Inputs menu
2. Teach output, Outputs menu

The Zeroing function sets the analog output to half of the output range, see Chap. 7.5.3.5.

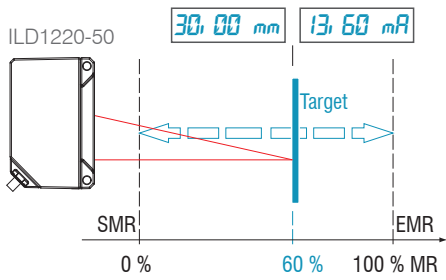

- ▶ Target at 60 %, zero setting
- ▶ Set minimum (m) 20 mm and maximum (n) 40 mm

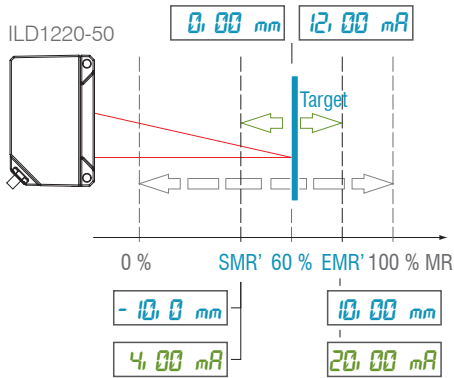

i $n < m$ generates an inverse characteristic curve.

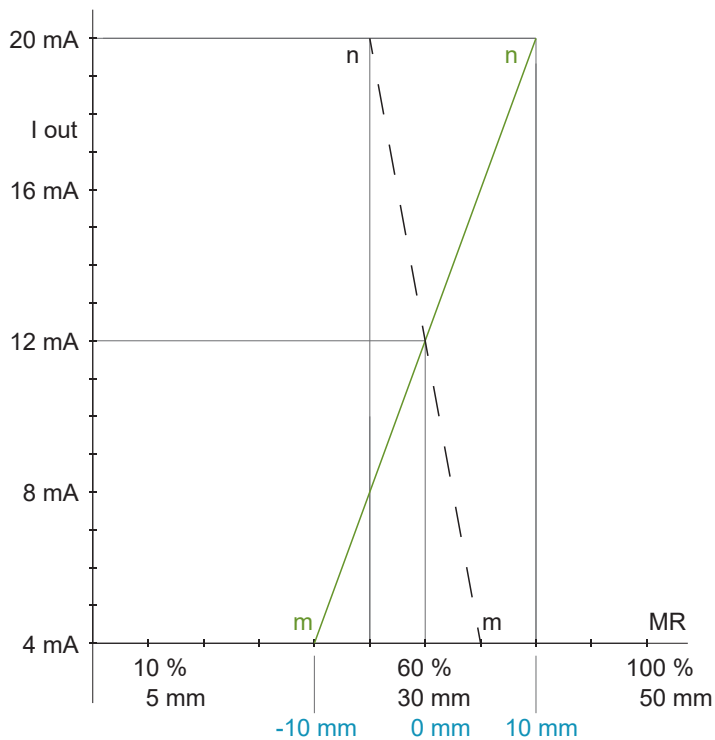

Fig. 7.15: Output characteristics after zeroing and scaling with an ILD1220-50

7.5.4 Error output

The switching output can be used for error or limit value monitoring at the output value.

Error output (switching output)	<i>Disabled</i>		<i>Controls the switching behavior of the switching output (error). Analog range: The switching output switches when the scaled analog range is exceeded. Measuring range: Switching output switches if the peak is not (completely) within the evaluation range (ROI), e.g. Measured object outside the measuring range or no measured object present. Limit value: The switching output switches when the limit value is exceeded.</i>			
	<i>Analog range / Measuring range</i>				<i>NPN / PNP / PushPull / PushPullNeg</i>	
	<i>limit monitoring</i>				<i>NPN / PNP / PushPull / PushPullNeg</i>	
	<i>limit monitoring</i>				Value	
	<i>Hysteresis</i>				Value	
	<i>Minimum time</i>	<i>hold</i>	Value			

The error output is activated depending on the set switching behavior, see Chap. 5.4.8.

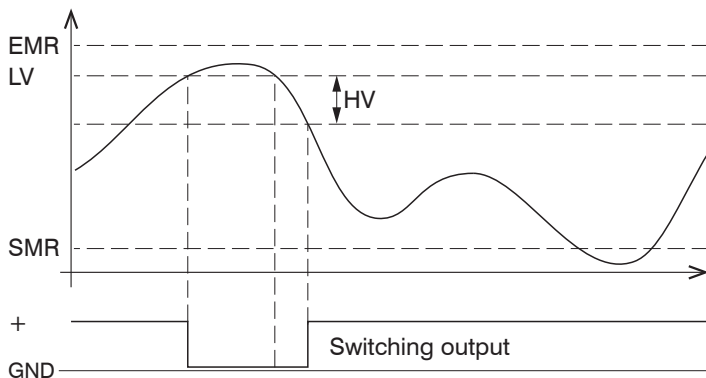

Fig. 7.16: Error output with limit value function, switching behavior (NPN)

- EMR = End of measuring range
- LV = limit monitoring
- HV = Hysteresis value
- SMR = Start of measuring range

The switching output is activated (conductive) when the limit value is exceeded and deactivated again when the hysteresis value is subsequently under-shot.

The switching output with `Measuring range` or `Limit value` function works independently of the analog output.

7.5.5 Data Output

The sensor interface used can be selected via the data output.

Active interface	LED Output	Data output possible via		
		Web interface	Current output	Digital Output
Web interface	Yellow	yes	---	---
Analog (factory setting)	Red		yes	---
RS422	Green	---	---	yes

Tab. 7.1: Options for data output

Data Output	<i>Web interface / Analog / RS422</i>	<i>Decides on the interface used for outputting the measured value. Parallel physical output of measurement values via RS422 and analog is not possible. If Web interface is selected, no measurement values are output via RS422 or the current output.</i>
-------------	---------------------------------------	--

7.6 System Settings

7.6.1 General

After programming, all settings must be saved permanently under a parameter set so that they are available again the next time the sensor is switched on.

7.6.2 Unit, language

The web interface supports units in millimeters (mm) and inches in the display of the measurement results. German, English, Chinese or Japanese can be selected as web interface language. Switch the language in the menu bar.

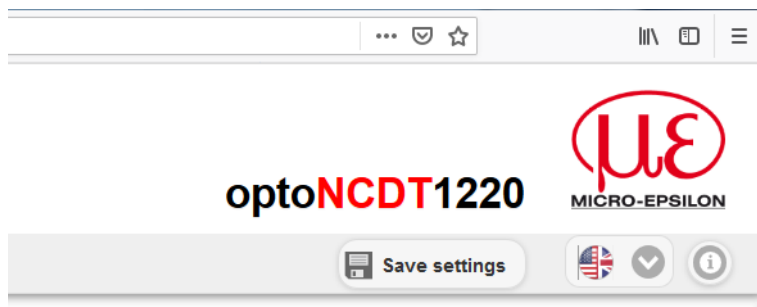

Fig. 7.17: Language selection in the menu bar

7.6.3 Key Lock

The key lock for the [Select](#), see [Chap. 5.3](#) key prevents unauthorized / unintended button operation. The key lock is activated when the user level `Operator` has been selected. The key lock can only be deactivated in the user level `Professional`. If an expert logs into the system, the sensor key lock is automatically released.

Key Lock	<i>Automatic</i>	<i>Range from 1 ... 60 [min]</i>	Value	<i>The key lock is activated after the defined time has elapsed. Click on the Refresh button to extend the time until the key lock is activated.</i>
	<i>Active</i>			<i>The Select button does not respond to inputs, regardless of the user level.</i>
	<i>Inactive</i>			<i>The Select button is active, regardless of the user level.</i>

7.6.4 Loading, saving

All the sensor settings can be saved permanently in user programs, which are known as setups.

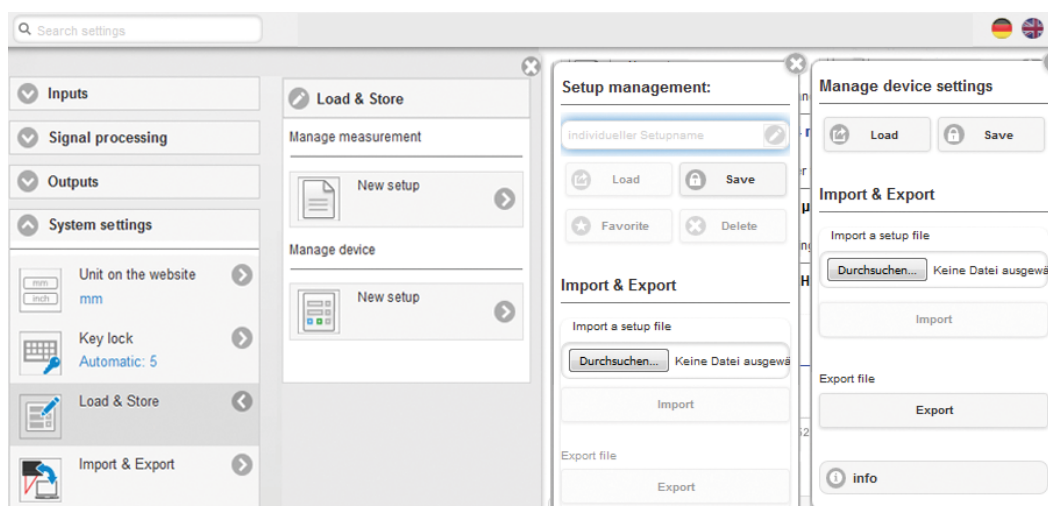



Fig. 7.18: Manage user programs

Manage setup in the sensor, options and procedure			
Saving the Settings	Activate existing setup	Save change in active setup	Determine setup after booting
New setup menu	Load & Save menu	Menu bar	Load & Save menu
Enter the name for the setup in the Individual setup name field, e.g. Shaft 4_02 and confirm the entry with the Save button.	Left-click on this setup. The following dialog opens: Measurement settings. Click on the Load button.	Click on the button 	Left-click on the setup. The following dialog opens: Measurement settings. Click on the Favorite button.

Exchange setup with PC/notebook, options	
Save setup on PC	Load setup from PC
Load & Save menu	Load & Save menu
Left-click on the setup. The Measurement settings dialog opens. Click on the Export button.	Left-click on New setup. The Measurement settings dialog opens. Click on the Browse button. A Windows dialog for file selection opens. Select the desired file and click the Open button. Click on the Import button.

7.6.5 Import, Export

A parameter set includes the current settings, setup(s) and the initial setup when booting the sensor.

The Import & Export menu allows you to easily exchange parameter sets with a PC/notebook.

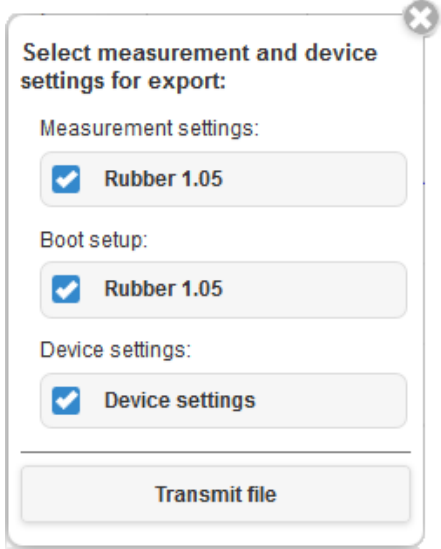
Exchange of parameter sets with PC/notebook, possibilities		
Storing parameter set on PC	Loading parameter set from PC	
Import & Export menu	Import & Export menu	
Left-click on the Create file button. The Choose export data dialog opens. Compose a parameter set by selecting/deselecting the checkboxes. Click on the Transmit file button. A Windows dialog for data transfer opens. Confirm the dialog with OK. The operating system stores the parameter set in the Download area. The file name for the adjacent example is <... \ Downloads \ ILD1220_50BASICSETTINGS_MEASSETTINGS_Wave 4_02... .JSON>	Click on the Browse button. A Windows dialog for file selection opens. Select the desired file and click on the Open button. The Choose import data dialog opens. Determine the operations to be performed by selecting/deselecting the checkboxes. Click on the Transmit file button.	

In order to avoid that an already existing setup is overwritten unintentionally during import, an automatic security request is carried out (see adjacent figure).

Options during import:

- Overwrite existing setups (with the same name)
- Apply settings of the imported boot setup

7.6.6 Access Authorization

Assigning passwords prevents unauthorized changes to sensor settings. The password protection is not activated in the delivery condition. The sensor operates at user level Professional. After the sensor has been configured, you should enable password protection. The standard password for the expert level is 000.

i A software update will not change the default password or a user-defined password. The Professional password is independent of the setup and is therefore not loaded or saved together with the setup.

Users have the following functions available:

Action	User	Professional
Password required	no	yes
Read inputs, signal processing, outputs, system settings	yes	yes
Change inputs, signal processing, outputs, system settings	no	yes
Change password	no	yes
Restore factory settings	no	yes

Tab. 7.2: Rights in the user hierarchy

Enter the standard password 000 or a user-defined password in the Password field and confirm your entry with Login.

Switch to the operating mode Operator by clicking on the Logout button.

Fig. 7.19: Switch to user level Professional

User management allows you to assign a user-defined password in the operating mode Professional.

Password	Value	All passwords are case-sensitive; numbers are allowed. Special characters are not permitted. The maximum length is limited to 31 characters.
User level on restart	User / Professional	Defines the user level that is enabled when the sensor starts the next time. Micro-Epsilon recommends the selection Operator.

After the sensor has been configured, you should enable password protection. Please write down the password for later use.

7.6.7 Resetting the sensor

Resetting the sensor	Sensor settings	Button	Deletes the baud rate, language, unit, key lock and echo mode settings and loads the default parameters.
	Measurement settings	Button	Deletes the settings for measuring rate, trigger, evaluation range, peak selection, error handling, averaging, zeroing/mastering, data reduction and the setups. Loads the 1st preset.
	Reset all	Button	Deletes the settings for the sensor, the measurement settings, the access authorization, password and the setups. Loads the 1st preset.
	Restart sensor	Button	Reboots the sensor with the settings from the favorites setup, see Chap. 7.6.4.

8 Digital interface RS422

8.1 Preliminary remarks

The RS422 interface has a maximum baud rate of 1 MBaud. The baud rate is set to 921.6 kBaud on delivery.

Data format: Measured values in binary format, commands as ASCII character string, little-endian

Interface parameters: 8 data bits, no parity, one stop bit (8N1).

i Only disconnect or connect the sensor to the USB converter when the power is switched off.

8.2 Measurement data format

Up to 18 bits per output value are transmitted, see Chap. 7.5.2.1. An output value is distributed over three bytes, which differ in the highest bits. The transfer of further output values is optional.

Output value 1:								
	Preamble		Data bits					
L-Byte	0	0	D5	D4	D3	D2	D1	D0
M-Byte	0	1	D11	D10	D9	D8	D7	D6
H-Byte	1	0	D17	D16	D15	D14	D13	D12

Output value 2 .. 32:								
	Preamble		Data bits					
L-Byte	0	0	D5	D4	D3	D2	D1	D0
M-Byte	0	1	D11	D10	D9	D8	D7	D6
H-Byte	1	1	D17	D16	D15	D14	D13	D12

Output sequence: L byte, M byte, H byte.

Depending on the measuring rate, baud rate and output data rate, all output data can be output in one block. If the output is not possible, a runtime error is issued. Data selection and output sequence can be queried with the `GETOUTIN-FO_RS422` command. The output of distance measurement values and other measured values via RS422 requires a subsequent conversion into the relevant unit, see Chap. 7.5.2.1.

8.3 Conversion of the binary data format

During conversion, the H byte, M byte and L byte must be recognized on the basis of the first two bits (identifier bits), the identifier bits removed and the remaining bits recombined to form a 16 or 18-bit data word.



Fig. 8.1: Result of the conversion

The conversion must always be done in the user program. D16 and D17 are used to evaluate the error codes or for the measured value counter, for example.

i The sensor can continue to supply measured values to the RS422 output even while the sensor is communicating.

The IF2001/USB from Micro-Epsilon is suitable for data exchange with a PC. The IF2001/USB combines the three bytes of the data word and stores them in the FIFO. The 18 bits are used for measurement and error values. Further information can be found in the descriptions of the IF2001/USB interface card and the associated MEDAQLib driver program.

You can find the current program routine at: www.micro-epsilon.de/link/software/medaqlib.

9 Cleaning

We recommend cleaning the protective glass at regular intervals.

Do not expose yourself to unnecessary laser radiation.

- ▶ Switch off the sensor for cleaning and maintenance.

Dry cleaning

This can be accomplished with an anti-static lens brush or by blowing off the windows with dehumidified, clean, oil-free compressed air.

Wet cleaning

Use a clean, soft, lint-free cloth or lens cleaning paper and pure alcohol (isopropanol) to clean the protective screen.

NOTICE

- ▶ Never use commercially available glass cleaners or other cleaning agents.

10 Software support with MEDAQLib

MEDAQLib is a documented driver DLL. This allows you to integrate sensors from Micro-Epsilon in conjunction with a converter or interface module into existing or customer-specific PC software.

MEDAQLib

- ▶ contains a DLL that can be imported into C, C++, VB, Delphi and many other programs,
- ▶ takes care of data conversion for you,
- ▶ works regardless of the type of interface used,
- ▶ uses the same functions for communication (commands),
- ▶ provides a uniform transmission format for all Micro-Epsilon sensors.

For C/C++ programmers, an additional header file and a library file are integrated into MEDAQLib.

- You can download the MEDAQLib installation files to your computer via the link <https://www.micro-epsilon.com/link/software/medaqlib>.
- For further information on MEDAQLib, please visit <https://www.micro-epsilon.com/service/software-sensorintegration/medaqlib>.

11 Disclaimer

All components of the device have been checked and tested for functionality in the factory. However, should any defects occur despite careful quality control, these shall be reported immediately to Micro-Epsilon or to your distributor / retailer.

Micro-Epsilon undertakes no liability whatsoever for damage, loss or costs caused by or related in any way to the product, in particular consequential damage, e.g., due to

- non-observance of these instructions/this manual,
- improper use or improper handling (in particular due to improper installation, commissioning, operation and maintenance) of the product,
- repairs or modifications by third parties,
- the use of force or other handling by unqualified persons.

This limitation of liability also applies to defects resulting from normal wear and tear (e.g., to wearing parts) and in the event of non-compliance with the specified maintenance intervals (if applicable).

Micro-Epsilon is exclusively responsible for repairs. It is not permitted to make unauthorized structural and / or technical modifications or alterations to the product. In the interest of further development, Micro-Epsilon reserves the right to modify the design or the firmware.

In addition, the General Terms of Business of Micro-Epsilon shall apply, which can be accessed under Legal details | Micro-Epsilon <https://www.micro-epsilon.com/legal-details/>.

12 Service, repair

If the sensor or sensor cables are defective:

- If possible, save the current sensor settings in a parameter set to reload them into the sensor after the repair.
- Please send us the affected parts for repair or exchange.

If the cause of a fault cannot be clearly identified, please send the entire system including cables to:

MICRO-EPSILON MESSTECHNIK
GmbH & Co. KG
Koenigbacher Str. 15
94496 Ortenburg / Germany

Tel: +49 (0) 8542 / 168-0
Fax: +49 (0) 8542 / 168-90
info@micro-epsilon.com
www.micro-epsilon.com/contact/worldwide/
<https://www.micro-epsilon.com>

13 Decommissioning, disposal

In order to avoid the release of environmentally harmful substances and to ensure the reuse of valuable raw materials, we draw your attention to the following regulations and obligations:

- Remove all cables from the sensor and/or controller.
- Dispose of the sensor and/or the controller, its components and accessories, as well as the packaging materials in compliance with the applicable country-specific waste treatment and disposal regulations of the region of use.
- You are obliged to comply with all relevant national laws and regulations.

For Germany / the EU, the following (disposal) instructions apply in particular:

- Waste equipment marked with a crossed garbage can must not be disposed of with normal industrial waste (e.g. residual waste can or the yellow recycling bin) and must be disposed of separately. This avoids hazards to the environment due to incorrect disposal and ensures proper recycling of the old appliances.



- A list of national laws and contacts in the EU member states can be found at https://ec.europa.eu/environment/topics/waste-and-recycling/waste-electrical-and-electronic-equipment-weee_en. Here you can inform yourself about the respective national collection and return points.

- Old devices can also be returned for disposal to Micro-Epsilon at the address given in the legal details at <https://www.micro-epsilon.com/legal-details>.

- We would like to point out that you are responsible for deleting the measurement-specific and personal data on the old devices to be disposed of.

- Under the registration number WEEE-Reg.-Nr. DE28605721, we are registered at the foundation Elektro-Altgeräte Register, Nordostpark 72, 90411 Nuremberg, as a manufacturer of electrical and/or electronic equipment.

14 Optional accessories

IF2001/USB

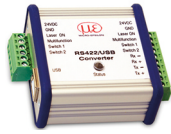

IF2001/USB 1-channel RS422/USB converter

Connections: 1 x 10-pin socket strip (cable clamp) type: Würth 691361100010, 1 x 6-pin socket strip (cable clamp), type: Würth 691361100006

IF2035-EtherCAT
IF2035-PROFINET
IF2035-EtherNet/IP



Interface module for connection to EtherCAT, PROFINET or EtherNet/IP of a Micro-Epsilon sensor with RS485 or RS422 interface; DIN rail housing, incl. device description file for software integration in the PLC

PS2020



Power supply unit for DIN rail mounting
Input 230 VAC, output 24 VDC/2.5 A

15 Factory settings

Password	„000“
Measuring rate	1kHz
Measuring range	100 % FSO: I = 20 mA, digital 64887
	0 % FSO: I = 4 mA, digital 643
Error Handling	Error output, no measured value

Language	German
Output	Current output
RS422	921.6 kBaud
Trigger mode	No trigger

Tab. 15.1: Factory setting Standard sensors

Balanced	Moving averaging with 64 values
Measuring rate	1kHz

Language	Chinese
RS422	115.2 kBaud

Tab. 15.2: Factory setting ILD1220-x(214) series sensors

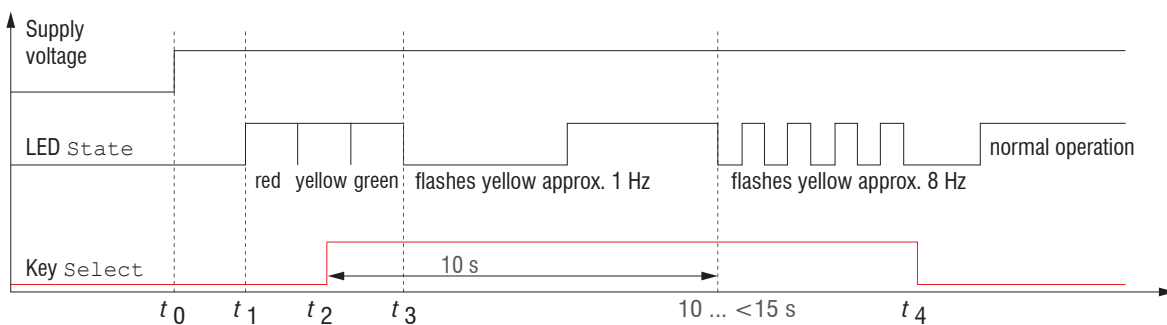

Fig. 15.1: Flowchart for starting a sensor with factory settings

- t_0 : Supply voltage is applied
- $t_1 \dots t_3$: Both LEDs signal the start sequence (red-yellow-green for 1 second each)
- t_2 : Select key is pressed during the start sequence ($t_1 \dots t_3$)
- t_4 : Select key is released while the State LED flashes yellow
 $\Delta t = t_4 - t_2$; Δt (keystroke duration) must be at least 10 seconds, max. 15 seconds

16 ASCII communication with sensor

16.1 General

The ASCII commands can be sent to the sensor via the RS422 interface. All commands, inputs and error reports are in English. A command always consists of the command name and zero or several parameters that are separated with a space and end in LF. If spaces are used in parameters, the parameter must be placed in quotation marks, e.g. "Password with space".

Example: Switching on output via RS422

```
OUTPUT RS422  ←␣
Note:         ←␣  Must contain LF, but can also be CR LF.
Explanation:  LF   Line feed (hex 0A)
              CR   Carriage return (hex 0D)
              ←␣  Enter (hex 0A or hex 0D0A depending on the system)
```

The currently set parameter value is reset if a command is invoked without parameters.

The entry formats are:

```
<Command name> <Parameter1> [<Parameter2> [...]]
<Command name> <Parameter1> <Parameter2> ... <Parameter...>
```

or a combination thereof.

Parameters in [] brackets are optional and require you to enter the preceding parameter. Successive parameters without [] brackets are required, i.e. no parameter can be omitted. Alternative entries for parameter values are separated by "|", e.g. the values "a", "b" or "c" can be set for "a|b|c". Parameter values in <> brackets can be selected from a value range.

Explanations on the format:	
"a b"	Parameter value can be set to the value "a" or "b".
" P1 P2"	Both parameters "P1" and "P2" must be set.
" P1 [P2 [P3]]"	The parameters "P1", "P2" and "P3" can be set, whereby "P2" can only be set if "P1" is set and "P3" can only be set if "P1" and "P2" are set.
"<a>"	Parameter value is within a value range of "... to ...", see parameter description.

Parameter values without angle brackets can only be discrete values, see parameter description. Round brackets should be interpreted as a grouping, i.e. for better comprehensibility, "P1 P2|P3" is written as "(P1 P2)|P3".

Example without []:

"PASSWD <Old password> <New password> <New password>" - All 3 parameters must be entered in order to change the password.

The output format is:

```
<Command name> <Parameter1> [<Parameter2> [...]]
```

The response can be used again without changes as a command for setting the password. Optional parameters are only returned as well if this is necessary. For example, for the data selection additional values command, only the activated output values are returned.

After a command is processed, a line break and a prompt ("->") is always returned. In the event of an error, an error message beginning with "Exxx", where xx stands for a unique error number, comes before the prompt. Moreover, instead of error messages, warning messages ("Wxxx") may be output. Warnings are structured analogously to error messages. In the case of warning messages, the command has been executed.

For support requests regarding the sensor, the responses to the commands GETINFO and PRINT are helpful because they contain the sensor settings.

16.2 Commands overview

Group	Command	Brief information
General		
	HELP	Help on commands
	GETINFO	Request sensor information
	LANGUAGE	Determine language of website
	RESET	Reboot sensor
	ECHO	Switch the command reply, ASCII interface
	PRINT	Output all sensor settings
User level		
	LOGIN	Changing the user level
	LOGOUT	Switch to User level
	GETUSERLEVEL	User level query
	STDUSER	Set the standard user
	PASSWD	Change password
Triggering		
	TRIGGER	Select trigger type
	MFILELEVEL	Select level for switching input
	TRIGGERCOUNT	Number of measurement values to be output
Interfaces		
	BAUDRATE	Set transmission rate of RS422
	UNIT	Select measurement unit of web interface
	MFIFUNC	Function selection multifunction input
	ERROROUT1	Activate switching output
	ERRORLEVELOUT1	Output level switching output
	ERRORLIMIT	Threshold value switching output
	ERRORHYSTERESIS	Hysteresis value switching output
	ERROROUTHOLD	Min. switching time of active switching output
Handling of setups		
	IMPORT	Loading parameters
	EXPORT	Export sensor settings
	MEASSETTINGS	Load/save measurement settings
	BASICSETTINGS	Load/save device settings
	SETDEFAULT	Factory settings
Scale analog output		
	ANALOGSCALE	Scale analog output
Key function		
	KEYFUNC	Select key function
	KEYLOCK	Set key lock
Measurement		
	MEASRATE	Select measuring rate
	LASERPOW	Select laser power
	MASTERMV	Mastering / zeroing
Data output		

Group	Command	Brief information
	OUTPUT	Measured value output selection
	OUTHOLD	Set error handling
	GETOUTINFO_RS422	Query data selection
	OUT_RS422	Selection of signals for data transmission
	OUTADD_RS422	Data selection of additional values

16.3 Commands

16.3.1 General commands

16.3.1.1 HELP

Output help for each command.

Command without parameters

- `<command>`
Command is executed

Command with parameters

- `<Command>`
Show current parameter values
- `<Command> <Parameter1> [<Parameter2> [...]]`
Set the parameters, the number of parameters varies
- `<Command> <Parameter1> <Parameter2> ... <Parameter...>`
Set the parameters, the number of parameters stays the same

Response to a command

- `->`: Cursor, the sensor is waiting for an entry
- `E<dd> <Msg>`: Error message, execution rejected
- `W<dd> <Msg>`: Warning message
- `<ddd>`: Three digits
- `<Msg>`: Message

Format explanation

- `()`: Grouping
- `[]`: Optional parameters
- `<>`: Placeholder
- `|`Alternative

If a parameter contains spaces, they must be placed in quotation marks.

Examples:

- `a|b`
Use a or b
- `a b`
Both parameters are required
- `a [b [c]]`
Non-fixed number of parameters: a, a b, or a b c
- `PASSWD <Old password>`
`<New password> <New password>`
All parameters are required to change the password.

16.3.1.2 GETINFO, Sensor Information

GETINFO

Request sensor information. Output see example below:

->GETINFO		
Name:	ILD1220-10	Sensor model name, sensor series
Serial:	20110036	Serial number
Option:	000	Option number of the sensor
Article:	4120260	Article number of the sensor
Cable head:	Wire	
Measuring range:	10.00mm	Measuring range of the sensor
Version:	001,062	Software version
Hardware-rev:	00	
Boot version:	001,006	
->		

16.3.1.3 LANGUAGE, Website

LANGUAGE DE | EN | CN | JP

Determines the language for the web interface

- DE: set language to German
- EN: set language to English
- CN: Set language to Chinese
- JP: Set language to Japanese

The website is displayed in the selected language.

16.3.1.4 RESET, Booting sensor

RESET

The sensor is restarted.

16.3.1.5 ECHO, Switching the Command Reply, ASCII Interface

ECHO ON|OFF

Setting the command reply with an ASCII command:

- ON: Command response on, e.g. <Kdo> ok (or error message)
->
- OFF: command reply off, e.g. ->

16.3.1.6 PRINT, Sensor Settings

PRINT

Print is used to output all sensor settings.

Example of a response:

GETUSERLEVEL PROFESSIONAL	OUTPUT RS422
STDUSER PROFESSIONAL	OUTADD_RS422 NONE
BAUDRATE 921600	GETOUTINFO_RS422 DIST1
UNIT MM	OUTHOLD NONE
LANGUAGE DE	ERROROUT1 DIST

```

MFIFUNC NONE          ERRORLEVELOUT1 NPN
MFILEVEL HTL_HIGH    ANALOGSCALE STANDARD
KEYFUNC TEACH        ERRORLIMIT DIST1 0.000
KEYLOCK AUTO 5 (IS_ACTIVE)  ERRORHYSTERESIS 0.100
MEASRATE 1.000      ERRORROUTHOLD 50
TRIGGER NONE         ->
TRIGGERCOUNT 1

```

16.3.2 User level

16.3.2.1 LOGIN, Change of the User Level

LOGIN <Password>

Enter the password to access another user level. There are the following user levels:

- USER (standard user): “read-only” access to all elements and graphical display of output values of web interface
- PROFESSIONAL (Expert): Read/write access to all elements

16.3.2.2 LOGOUT, Change into User Level

LOGOUT

Sets the user level to USER.

16.3.2.3 GETUSERLEVEL, User level query

GETUSERLEVEL

Queries the current user level.

16.3.2.4 STDUSER, Set Standard User

STDUSER USER|PROFESSIONAL

Sets the standard user who is logged in after the system starts. Standard user does not change with LOGOUT, i.e. login as standard user is done automatically after the command RESET or power supply of sensor is switched on.

16.3.2.5 PASSWD, Change Password

PASSWD <Old password> <New password> <New password>

Changes the password for the PROFESSIONAL level.

The old password must be entered once, and the new password twice. If the new passwords do not match, an error message is displayed. A password may only contain letters (A to Z) and numbers, but no letters with accents or umlauts. Upper and lower case are distinguished. The maximum length is limited to 31 characters.

16.3.3 Triggering

The multifunction input also serves as a trigger input for the output of measured values.

16.3.3.1 TRIGGER, Trigger selection

TRIGGER NONE|EDGE|PULSE

- NONE: No triggering
- PULSE: Level triggering
- EDGE: Edge triggering

16.3.3.2 MFILELEVEL, Input Level Multi-Function Input

MFILELEVEL HTL_HIGH|HTL_LOW

Selection of switching or trigger level for the multi-function input

- HTL_HIGH: High active (edge triggering: rising edge, level triggering: high active)
- HTL_LOW: Low active (edge triggering: falling edge, level triggering: low active)

16.3.3.3 TRIGGERCOUNT, Number of Output Measurement Values

TRIGGERCOUNT NONE | INFINITE | <n>

<1...16382>

Number of Output Measurement Values with Triggering

- NONE: End triggering and start continuous output
- INFINITE: Start of continuous output after first trigger event
- <n>: Number of values to be output after each trigger event n = 1 to 16382.

16.3.4 Interfaces

16.3.4.1 BAUDRATE, RS422

BAUDRATE 9600|19200|56000|115200|128000|230400|256000|460800|691200|921600|1000000

Sets the baud rate for the RS422 interface.

16.3.4.2 UNIT, Measurement unit of web interface

UNIT MM|INCH

Changes the display of measured values on the websites. The command has no influence on the ASCII interface.

- MM Values are displayed in mm
- INCH Values are displayed in inches

16.3.4.3 MFIFUNC, Function selection multifunction input

MFIFUNC NONE | MASTER | TEACH | TRIGGER

Select the function of the multifunction input.

- NONE: Multifunction input has no function
- MASTER: Multifunction input is master pulse input
- TEACH: Multifunction input is teach input for analog output
- TRIGGER: Multifunction input is trigger input

16.3.4.4 ERROROUT1, Activate switching output

ERROROUT1 NONE|DIST|TEACH|LI1

Choose error signal of the ERROR switching output.

- NONE: Switching output deactivated
- DIST: no peak found or beyond measuring range (out of range)
- TEACH: Distance is out of scaled analog range
- - LI1: Distance is greater than the limit value (ERRORLIMIT)

16.3.4.5 ERRORLEVELOUT1, Output level switching output

ERRORLEVELOUT1 NPN|PNP|PUSHPULL|PUSHPULLNEG

Choice of output level for ERROROUT1.

- NPN: Switching output is active in the event of an error.
- PNP: Switching output is active in event of error.
- PUSH/PULL: Switching output is high in event of error.
- PUSH/PULL/NEG: Switching output is low in event of error.

Wiring of the switching output ERROR1, see Chap. 5.4.8

16.3.4.6 ERRORLIMIT

ERRORLIMIT DIST1 <upper threshold>

Value which activates switching output when exceeded.

Value range: -2 ... 2 * measuring range [mm].

16.3.4.7 ERRORHYSTERESIS

ERRORHYSTERESIS <hysteresis>

Value by which the measured value must fall short of the limit value to deactivate the switching output. Value range: 0 ... 2 * measuring range [mm].

16.3.4.8 ERROROUTHOLD

ERROROUTHOLD [<hold period [ms]>]

Specification of the minimum time in ms for which the switching output should remain active if the limit value is exceeded. The time period begins when the limit value is exceeded. Value range: 0 ... 1000 [ms].

16.3.5 Handling of setups

16.3.5.1 IMPORT

IMPORT [FORCE] [APPLY] <ImportData>

Importing data in JSON format ^[10] into the sensor.

First, the import command returns a prompt (->). Afterwards, data can be sent. After importing a prompt (->) is returned.

- FORCE: Overwriting measurement settings (= MEASSETTINGS) with the same name (otherwise an error message is displayed if the names are the same). FORCE must always be specified when importing all measurement settings or the device settings (= BASICSETTINGS).
- APPLY : Activates the settings after importing / reading the Initial Settings.
- ImportData: Data in JSON format

16.3.5.2 EXPORT

EXPORT (MEASSETTINGS <SettingName>) | BASICSETTINGS | MEASSETTINGS_ALL | ALL

Exporting the sensor settings. In response, the data is transferred in JSON format. Finally, there is another prompt.

- MEASSETTINGS: Exports the measurement settings with the name <SettingName>.
- BASICSETTINGS: Exports the device settings.
- MEASSETTINGS_ALL: Exports the measurement settings.
- ALL: Exports measurement and device settings.

16.3.5.3 MEASSETTINGS, Load / Save Measurement Settings

MEASSETTINGS <Subcommand> [<Name>]

Settings for measurement task.

Loads manufacturer-defined presets or a user-specific setup from the sensor or saves a user-specific setup in the sensor.

[10] JSON format, see https://de.wikipedia.org/wiki/JavaScript_Object_Notation

Subcommands:

- CURRENT: Output of the name of the current measurement setting.
- PRESETLIST: Lists all existing presets.
- LIST: Lists all saved measurement settings.
- READ <name>: Load a preset or a measurement setting from the sensor.
- STORE <name, new>: Save the current measurement setting in the sensor.
- DELETE <Name>: Deletes a measurement setting.
- RENAME <NameOld> <NameNew> [FORCE]: Rename a measurement setting. An existing measurement setting can be overwritten with FORCE.
- INITIAL AUTO: Load the last saved measurement setting when the sensor is started.
- INITIAL <name>: Load a named measurement setting when the sensor is started.
- PRESETMODE: Return the set signal quality.
- PRESETMODE <mode>: Set the signal quality. The signal quality can only be set if a preset has been loaded.
 - <mode> = BALANCED|DYNAMIC|NOAVERAGING

Names:

- <name>: Name of a manufacturer setup or a user-specific setup.
- <name new>: Name of a user-specific setup. Names must have at least two characters and are limited to max. 31 characters. Letters from A to Z without umlauts and numbers are allowed, the name is case-sensitive. Preset names are not permissible, a name should not begin with "Auto".

16.3.5.4 BASICSETTINGS, Load/Save Device Settings

BASICSETTINGS READ | STORE

- READ: Loads the saved device settings from the sensor.
- STORE: Saves the current device settings in the sensor.

Most of the settings belong to the Measurement settings group. The following commands enable the configuration of the device settings:

- BAUDRATE
- ECHO
- KEYLOCK
- LANGUAGE
- PASSWD
- UNIT

16.3.5.5 SETDEFAULT, factory settings

SETDEFAULT ALL | MEASSETTINGS | BASICSETTINGS

Resets the sensor to factory settings.

- ALL: Deletes the measurement and device settings and loads the standard presets for the measurement settings and default parameters for the device settings.
- MEASSETTINGS: Deletes the measurement settings and loads the standard presets.
- BASICSETTINGS: Deletes the device settings and loads the default parameters.

16.3.6 ANALOGSCALE, Scaling the analog output

ANALOGSCALE STANDARD|(TWOPOINT <minimum value> <maximum value>)

Set the two-point scaling of the analog output.

- STANDARD: Utilize the measuring range of the sensor.
- TWOPOINT: Two-point scaling within the analog range (4 - 20 mA).
 - Minimum value: Measured value in mm that is assigned to the lower analog value (4 mA).

- Maximum value: Measured value in mm that is assigned to the upper analog value (20 mA).

i The minimum value (in mm) can be greater than the maximum value (in mm), see Chap. 7.5.3.

16.3.7 Key function

16.3.7.1 KEYFUNC, Select key function

KEYFUNC NONE | MASTER | TEACH

Selection of key function.

- NONE: Key has no function.
- MASTER: Use key for mastering.
- TEACH: Use key for teaching.

16.3.7.2 KEYLOCK, Set Keylock

KEYLOCK NONE | ACTIVE | AUTO <time>

Selection of the key lock.

- NONE: Key is activated continuously, no key lock.
- ACTIVE: Key lock is activated immediately after restart.
- AUTO: Key lock is only activated <time> minutes after a restart.
 - <Time> Range between 1 ... 60 minutes

16.3.8 Measurement

16.3.8.1 MEASRATE, Measuring rate

MEASRATE 0.25|0.5|1|2

Selection of the measuring rate in kHz.

16.3.8.2 LASERPOW, Laser Power

LASERPOW FULL | OFF

- FULL: Laser power is switched to 100 %.
- OFF: Laser is switched off.

16.3.8.3 MASTERMV, Mastering / zeroing

MASTERMV NONE|MASTER <MV>

- NONE: Ends the mastering.
- MASTER: Setting the current measured value as the master value.
- MV: Master value in millimeters; $MV = (0 \dots 2) * \text{Measuring range}$, i.e. the master value must be within the measuring range.

If the master value is 0, the mastering function has the same functionality as the zero setting. When mastering the analog output, the parameter MV always acts as 0 (zero setting) regardless of the input.

The master command waits for a maximum of 2 seconds for the next measurement value and uses this as master value. If no value is measured within this time, e.g. in case of external triggering, the command returns with the error „E220 Timeout“.

The master value is processed with six decimal places.

Please note that the output value is limited to 18 bits.

16.3.9 Data Output

16.3.9.1 OUTPUT, Selection of Measurement Value Output

OUTPUT NONE | RS422 | ANALOG

- NONE: No output of measured values
- RS422: Output of measured values via RS422
- ANALOG: Output of measurement values via analog output

16.3.9.2 OUTHOLD, Error Handling

OUTHOLD NONE | INFINITE | <n>

Sets the measured value output behavior in the event of an error.

- NONE: Last measured value not held; error value output.
- INFINITE: Infinite holding of the last measurement value.
- <n>: Holding the last measured value over n measuring cycles; then an error value is output. n = (1 ... 1024).

16.3.9.3 GETOUTINFO_RS422, Data Selection Query

GETOUTINFO_RS422

The command lists all output data selected for the RS422 interface. The order shown corresponds to the output order.

16.3.9.4 OUT_RS422

OUT_RS422 NONE | ([DIST1] [COUNTER])

This command is used to choose the signals for measurement data output via the RS422 interface.

- DIST1: Calibrated distance value
- COUNTER: measured value counter
- NONE: No value output

16.3.9.5 OUTADD_RS422, Data Selection of Additional Values

OUTADD_RS422 NONE | COUNTER

Selection of additional values to be transmitted.

- NONE: No output of any further values
- COUNTER: Output of the measured value counter

16.4 Error Messages

If an error occurs with a command, the error message is listed.

Error message		Description
E100	Internal error	Internal error code
E104	Timeout	Timeout during mastering
E200	I/O operation failed	Cannot write data on output channel.
E202	Access denied	Access denied; requires login as expert.
E204	Received unsupported character	An unsupported character has been received.
E210	Unknown command	Unknown command (insufficient rights for reading)
E214	Entered command is too long to be processed	The specified command with the parameters is too long (greater than 255 bytes).
E220	Timeout, command aborted	Timeout beim Mastern
E232	Wrong parameter count	Number of parameters too high or too low

Error message		Description
E234	Wrong or unknown parameter type	A transmitted parameter has the wrong type or the wrong number of parameters has been passed.
E236	Value is out of range or the format is invalid	The parameter value is outside the range of values.
E262	Active signal transfer, please stop before	One measurement data output is active. End the measurement data output in order to execute the command.
E320	Wrong info-data of the update	Only when updating: the header of the update data contains an error
E321	Update file is too large	Only with update: The update is too large.
E322	Error during data transmission of the update	Only when updating: Error when transferring the update data
E323	Timeout during the update	Only when updating: Timeout when transferring update data
E331	Validation of import file failed	Import file is invalid.
E332	Error during import	Error with processing import data.
E333	No overwrite during import allowed	No overwrite of measurement and device settings allowed through import. Setting checkbox.
E350	The new passwords are not identical	Error when repeatedly entering the new password
E360	Name already exists or not allowed	Name for the measurement setting already exists or is not permitted.
E361	Name begins or ends with spaces or is empty	Name for the measurement setting begins or ends with a space or is empty.
E362	Storage region is full	Number of storable measurement settings is reached.
E363	Setting name not found	Name of the measurement setting to be loaded not found.
E364	Setting is invalid	Measurement setting or device setting is invalid.
E602	Master value is out of range	The master value is outside the valid range.
E616	Software triggering is not active	Software trigger is not active.

Warning		Description
W320	The measuring output has been adapted automatically.	The measurement value output has been adapted automatically.

Index



MICRO-EPSILON MESSTECHNIK GmbH & Co. KG
Koenigbacher Str. 15 94496 Ortenburg / Germany
Tel. +49 (0) 8542 / 168-0 Fax +49 (0) 8542 / 168-90
info@micro-epsilon.com <https://www.micro-epsilon.com>
Your local contact: www.micro-epsilon.com/contact/worldwide/

X9751406-B082036EKA
© MICRO-EPSILON MESSTECHNIK