



Operating Instructions
optoNCDT ILR3800

ILR3800-100
ILR3800-100-H
ILR3800-100-IO

Non-contact laser-optic distance sensor

MICRO-EPSILON Eltrotec GmbH
Manfred-Wörner-Straße 101

73037 Göppingen / Germany

Tel. +49 (0) 7161 / 98872-300
Fax +49 (0) 7161 / 98872-303
e-mail info@micro-epsilon.com
www.micro-epsilon.com

Inhalt

1.	Safety	5
1.1	Symbols used	5
1.2	Warnings	5
1.3	Notes on product marking	6
1.3.1	CE marking	6
1.3.2	UKCA marking	6
1.4	Intended use	6
1.5	Proper environment	6
2.	Laser safety	7
3.	Functional principle, technical data	8
3.1	Short description	8
3.2	Measuring principle	8
3.3	Term definitions, analog output for displacement	8
3.4	Technical data	9
4.	Delivery	10
4.1	Unpacking, included in delivery	10
4.2	Storage	10
5.	Installation and assembly	11
5.1	Notes for operation	11
5.1.1	Reflectance of target surface	11
5.1.2	Laser spot diameter, min. target size	11
5.1.3	Interferences	12
5.1.3.1	Ambient light	12
5.1.3.2	Thermal influences	12
5.1.3.3	Mechanical vibrations	12
5.1.3.4	Motion blur	12
5.1.3.5	Angular influences	12
5.2	Mechanical fastening	13
5.2.1	Sensor mounting	13
5.2.2	Start of measuring range	14
5.2.3	Reflector setup	14
5.2.4	Vertical and horizontal laser line correction	14
5.3	Indicator elements	15
5.4	Electrical connections ILR3800-100	16
5.4.1	Connection possibilities	16
5.4.2	Pin assignment	17
5.4.3	Supply voltage	18
5.4.4	Analog output	18
5.4.5	RS422 (with IF2001/USB converter)	19
5.4.6	Multifunction input	19
5.4.7	Triggering	19
5.5	Electrical connections ILR3800-100-IO	20
5.5.1	Connection possibilities	20
5.5.2	Pin assignment	20
5.5.3	Supply voltage	20
6.	Operation ILR3800-100	21
6.1	Getting ready for operation	21
6.2	Operation using sensorTOOL	21
6.3	Data acquisition, presets	23
6.4	Masking the region of interest, ROI	23
6.5	Triggering	24
6.5.1	General	24
6.5.2	Triggering data acquisition	25
6.5.3	Triggering measured value output	25
6.6	Mastering	26
6.7	Analog output	27
6.7.1	Scaling	27
6.7.2	Calculation of the measured value from the current output	27
6.8	Measurement hold mode, error handling	28
6.9	System settings	28
6.9.1	Saving the settings	28
6.9.2	Language	28
6.10	ILR3800-100-H with heating element	28
7.	Operation ILR3800-100-IO	29
7.1	Getting ready for operation	29
7.2	Operation using IO-Link	29
7.3	Process data	29
7.4	Device data	29
8.	Digital interface RS422	30
8.1	Preliminary remarks	30
8.2	Measurement data format	30
8.3	Binary error values	31
8.4	Resetting the sensor	32

9.	Cleaning	33
10.	Software support with MEDAQLib	33
11.	Disclaimer	34
12.	Service, repair	34
13.	Decommissioning, disposal	34
Appendix		
A 1	Optional accessories	35
A 2	Mounting plate	37
A 3	Factory settings	38
A 3.1	ILR3800-100.....	38
A 3.2	ILR3800-100-IO	38
A 4	ASCII Communication with Sensor	39
A 4.1	General	39
A 4.2	Commands overview	40
A 4.3	General commands	41
A 4.3.1	HELP	41
A 4.3.2	GETINFO	41
A 4.3.3	GETTEMP	41
A 4.3.4	PRINT.....	42
A 4.3.5	PRINT ALL	42
A 4.3.6	RECOVERY.....	42
A 4.3.7	RESET.....	42
A 4.3.8	RESETCNT	42
A 4.3.9	MFIFUNC	42
A 4.3.10	TRIGGER	43
A 4.3.11	TRIGGERAT	43
A 4.3.12	TRIGGERLEVEL	43
A 4.3.13	TRIGGERCOUNT	43
A 4.3.14	TRIGGERSW.....	43
A 4.3.15	MASTER SET.....	43
A 4.3.16	MASTERSIGNAL	43
A 4.4	Interfaces	44
A 4.4.1	BAUDRATE	44
A 4.4.2	OUTHOLD.....	44
A 4.5	Setup and measurement settings	44
A 4.5.1	MEASSETTINGS	44
A 4.5.2	BASICSETTINGS.....	44
A 4.5.3	SETDEFAULT	44
A 4.5.4	LASER.....	44
A 4.5.5	ROI.....	44
A 4.6	Data output	45
A 4.6.1	OUTPUT.....	45
A 4.6.2	GETOUTINFO_RS422	45
A 4.6.3	OUTADD_RS422.....	45
A 4.6.4	ANALOG_SCALERANGE	45
A 4.7	ASCII Error Codes	46

1. Safety

1.1 Symbols used

System operation assumes knowledge of the operating instructions.

The following symbols are used in these operating instructions:



Indicates a hazardous situation which, if not avoided, may result in minor or moderate injury.



Indicates a situation that may result in property damage if not avoided.



Indicates a user action.



Indicates a tip for users.

Measurement

Indicates hardware or a software button/menu.

1.2 Warnings



Connect the power supply according to the safety regulations for electrical equipment.

- > Risk of injury
- > Damage to or destruction of the sensor



Avoid shocks and impacts to the sensor.

- > Damage to or destruction of the sensor

The supply voltage must not exceed the specified limits.

- > Damage to or destruction of the sensor

Install the sensor on a flat surface using only the mounting holes/threaded holes provided, any type of clamping is not permitted.

- > Damage to or destruction of the sensor

Protect the cables against damage.

- > Damage to or destruction of the sensor

- > Failure of the measuring device

Do not operate the sensor if optical components are steamed up or dirty.

- > Failure of the measuring device

Do not touch the lenses or protective windows. Remove any fingerprints immediately using pure alcohol and a clean cotton cloth without leaving any streaks.

- > Damage to or destruction of the sensor

- > Failure of the measuring device

1.3 Notes on product marking

1.3.1 CE marking

The following apply to the product:

- Directive 2014/30/EU ("EMC")
- Directive 2011/65/EU ("RoHS")

Products which carry the CE marking satisfy the requirements of the EU Directives cited and the relevant applicable harmonized European standards (EN). The product is designed for use in industrial and laboratory environments.

The EU Declaration of Conformity and the technical documentation are available to the responsible authorities according to the EU Directives.

1.3.2 UKCA marking

The following apply to the product:

- SI 2016 No. 1091 ("EMC")
- SI 2012 No. 3032 ("RoHS")

Products which carry the UKCA marking satisfy the requirements of the directives cited and the relevant applicable harmonized standards. The product is designed for use in industrial and laboratory environments.

The UKCA Declaration of Conformity and the technical documentation are available to the responsible authorities according to the UKCA Directives.

1.4 Intended use

- The optoNCDT ILR3800 is designed for use in industrial and laboratory applications. It is used for
 - Distance, displacement and position measurement
 - Monitoring quality and checking dimensions
- The system must only be operated within the limits specified in the technical data, see [Chap. 3.4](#).
- The system must be used in such a way that no persons are endangered or machines and other material goods are damaged in the event of malfunction or total failure of the system.
- Take additional precautions for safety and damage prevention in case of safety-related applications.
- When measuring on reflectors or shiny surfaces, keep a distance of at least 35 m to avoid damage to sensor components caused by the reflected light. The visible point of light of the measurement laser should be in the center of the reflector.

1.5 Proper environment

- Protection class: IP67 (applies only when sensor cable is plugged in)

The protection class does not apply to optical entries, as contamination will impair or prevent their function.

- Temperature range:
 - Operation: -10 ... +50 °C, heating element -40 °C up to +50 °C
 - Storage: -25 ... +70 °C
- Humidity: 5 ... 95 % RH (non-condensing)
- Ambient pressure: Atmospheric pressure

2. Laser safety

The optoNCDT ILR3800 sensor operates with a semiconductor laser with a wavelength of 655 nm (visible/red).

The sensors fall within laser class 2. The laser is pulsed; the maximum optical power is ≤ 1 mW. The pulse frequency depends on the measuring rate set (1 ... 20 Hz). The pulse duration of the peaks is controlled depending on the measuring rate and the reflectivity of the measuring object and can be 0.2 ... 0.8 ns.



VORSICHT

Laser radiation. Eyes could become irritated or damaged.
Close your eyes, or immediately turn away if the laser beam hits the eye.

i Observe the national laser regulations!

Relevant regulations must be observed when operating the sensors. The following apply accordingly:

- With class 2 laser devices, the eye is not endangered by random, brief exposure to laser radiation, i.e. exposure times of up to 0.25 s.
- Class 2 laser devices may therefore be used without further protective measures if you do not intentionally look into the laser beam or into specular-reflected radiation for more than 0.25 s.
- Because the presence of the eyelid protective reflex should not normally be assumed, one should deliberately close the eyes or turn away immediately if the laser beam hits the eye.

Lasers of Class 2 are not subject to notification and a laser protection officer is not required.

The following signs are attached to the sensor housing (front) see [Abb. 1](#):



Abb. 1 Laser warning and laser information sign, optoNCDT ILR 3800-100, IEC

The German laser information sign is enclosed.

i If the information signs are covered over when the unit is installed, the user must ensure that supplementary information signs are attached at the installation location.

Operation of the laser is indicated visually by the `Status` LED on the sensor, see [Chap. 5.3](#).

The optoNCDT ILR3800 housings may only be opened by the manufacturer, see [Chap. 11](#).

For repair and service purposes, the sensors must always be sent to the manufacturer.

Observe national regulations, e.g., the German Occupational Health and Safety Ordinance on Artificial Optical Radiation (OStrV).

Recommendations for the operation of sensors that emit laser radiation in the visible or non-visible range can be found in DIN EN 60825-1 (from 07/2022), among others.

3. Functional principle, technical data

3.1 Short description

The optoNCDT ILR3800 is a laser distance measuring device that precisely measures distances in the range from 0.05 m to 150 m without contact and with millimeter precision. The measurement target can be clearly identified by the red laser measuring point. The maximum range depends on the reflectivity and surface properties of the target.

The device works on the basis of phase comparison measurement. High-frequency modulated laser light is emitted in the process. The light diffusely reflected and phase-shifted by the measuring object is compared with the reference signal. The magnitude of the phase displacement makes it possible to determine the distance to the nearest millimeter.

The distance measurement can be started in various ways:

- A command can be sent by a PC or another control unit via a serial RS422 interface
- External triggering
- Using the Autostart function

3.2 Measuring principle

Light in the visible wavelength range is modulated with suitably chosen frequencies such that the exact distance can be derived from the multiple of the relevant modulation wavelength contained in the distance to be measured and from the size of the remaining interval. The remaining interval is measured using analog phase comparison methods. Several modulation waves are used to determine the distance.



Abb. 2 Evaluation of the phase displacement for determining the distance

3.3 Term definitions, analog output for displacement

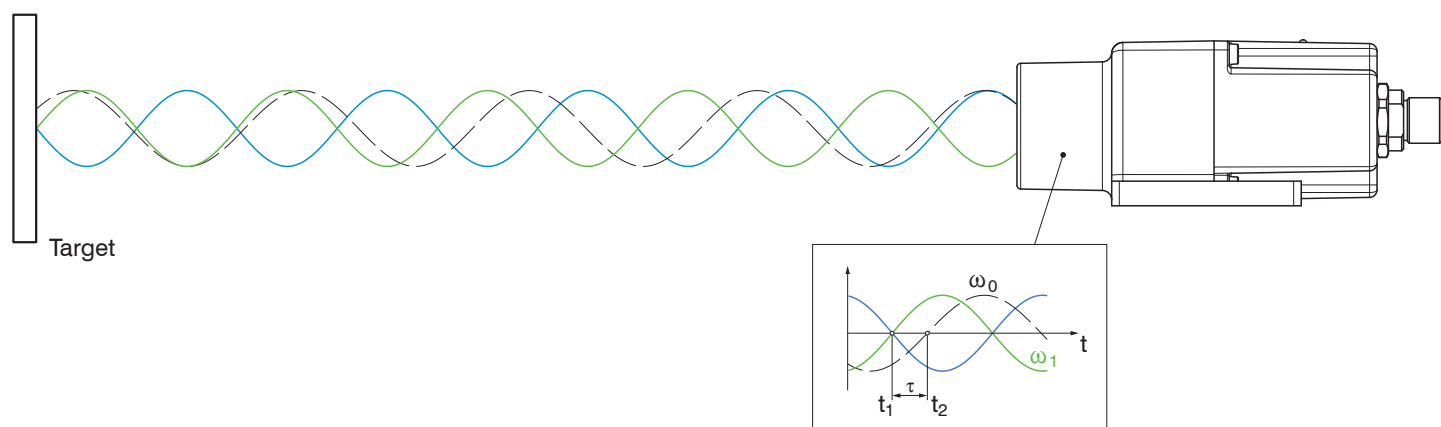
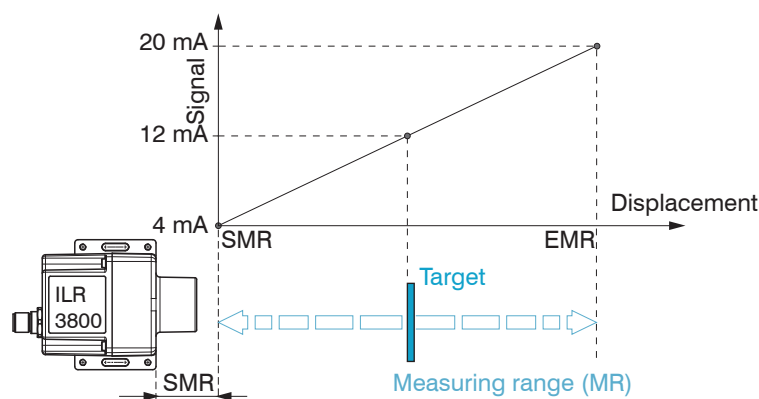

- SMR Start of measuring range, minimum distance between sensor and target
- EMR End of measuring range (start of measuring range + measuring range), maximum distance between sensor and target
- MR Measuring range

3.4 Technical data

Model		ILR3800-100	ILR3800-100-H	ILR3800-100-IO	
Measuring range [1]	Black 6 %	Start of measuring range	0.05 m		
		End of measuring range	30 m		
	Gray 40 %	Start of measuring range	0.05 m		
		End of measuring range	70 m		
	White 80 %	Start of measuring range	0.05 m		
		End of measuring range	100 m		
	Reflector film	Start of measuring range	35 m		
		End of measuring range	150 m		
Measuring rate		20 Hz			
Resolution		0.1 mm			
Linearity		< ± 1 mm [2]			
Repeatability [3]		< 300 µm			
Temperature compensation		-10 ... +50 °C	-40 ... +50 °C	-10 ... +50 °C	
Light source		Semiconductor laser < 1 mW, 655 nm (red)			
Typ. service life		50,000 h			
Laser class		Class 2 in accordance with DIN EN 60825-1: 2022-07			
Permissible ambient light		50,000 lx			
Supply voltage		10 ... 30 VDC	24 ... 30 VDC	10 ... 30 VDC	
Power consumption		< 1.5 W (24 V)	< 10 W (24 V)	< 1.5 W (24 V)	
Signal input		Trigger		-	
Digital interface		RS422 / USB/ PROFINET/ EtherNet/IP [4]		IO-Link 1.1; process data, parameter set up and diagnos- tics	
Analog output		4 ... 20 mA (16 bit, freely scalable within the measuring range)		-	
Connections		Supply/signal: M12 screw/plug connection 8-pin A-coded		Supply/sig- nal: M12 5-pin screw/plug connection	
Mounting		Screwing and adjustment on sensor base plate			
Temperature range	Storage	-25 ... +70 °C (non-condensing)			
	Operation	-10 ... +50 °C (non-condens- ing)	-40 ... +50 °C (non-condens- ing)	-10 ... +50 °C (non-condens- ing)	
Shock (DIN EN 60068-2-29)		15 g / 6 ms in 3 axes, in 3 directions, 1000 shocks each			
Vibration (DIN EN 60068-2-6)		15 g / 10 ... 500 Hz in 3 axes, 10 cycles each			
Protection class (DIN EN 60529)		IP67			
Material		Aluminum housing and plastic cap			
Weight		207 g	217 g	207 g	
Control and indicator elements		2x LEDs for power, signal strength = status			

[1] The specified data apply at a constant room temperature of 20 °C with continuous sensor operation. Measurements were taken on a white, diffusely reflective surface (reference ceramic). Reflector film RF250

[2] Measured in the range of 0.05 ... 20 m; statistical spread 2σ

[3] Measurement frequency of 20 Hz, moving average 10

[4] Connection via interface module (see accessories)

4. Delivery

4.1 Unpacking, included in delivery

1 Sensor ILR3800-100

1 Setup guide

1 German laser information sign

1 Assembly screw set including:

- 2 x Hex socket head cap screws M4x12
- 2 x Spring washers M4
- 4 x Set screws hexagon socket M4x6

► Carefully remove the components of the measuring system from the packaging and ensure that the goods are forwarded in such a way that no damage can occur.

► Check the delivery for completeness and shipping damage immediately after unpacking.

► If there is damage or parts are missing, immediately contact the manufacturer or supplier.

Optional accessories are listed in the appendix, see [Chap. A 1](#).

4.2 Storage

Temperature range for storage: -25 ... +70 °C (-13 ... 158 °F)

Humidity: 5 ... 95 % RH (non-condensing)

5. Installation and assembly

5.1 Notes for operation

5.1.1 Reflectance of target surface

The optoNCDT ILR 3800-100 sensor is an optical system used to measure in the millimeter range. The sensor works based on the phase comparison method and evaluates the direct and diffuse reflections of the laser beam sent back.



Abb. 3 Reflectance of target surface

The ILR3800-100 sensor is able to work with a reflectivity between 6 % and 100 %.

It is not possible to predict the signal strength for various surfaces due to the myriad environmental influences. The color and surface properties of the target as well as incident ambient light and meteorological influences can all affect the signal quality.

The expected signal quality can be estimated based on the color of the target.

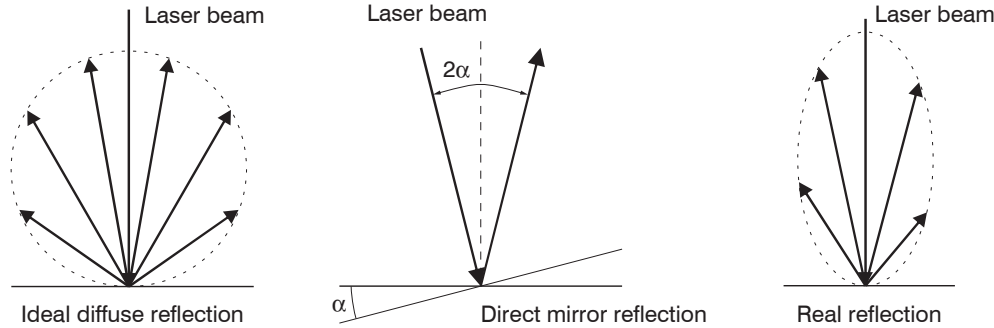
Color impression	Reflection	Maximum range	Comparable material
Black	6 - 15 %	30 meters	Cardboard, paper, fabric, felt
Gray	30 - 50 %	70 meters	Concrete, gray hall wall
White	80 - 90 %	100 meters	White paper, light wall
Reflector	100 %	150 meters	ILR-RF210 reflector film

The `AUTO Measurement` mode is recommended for dark, reflective and distant targets. This measurement mode optimizes the measuring frequency of the sensor, depending on the signal quality, and therefore provides the best results even in difficult conditions.

5.1.2 Laser spot diameter, min. target size

The laser spot diameter increases with increasing distance (displacement). Keep this in mind for the selection/size of the target. The measuring object must be at least three times the size of the laser spot.



Abb. 4 Laser spot dimensions and size of measuring object depending on the distance

5.1.3 Interferences

5.1.3.1 Ambient light

The optoNCDT ILR3800 series sensors achieve high ambient light immunity through integrated optical interference filters. Nevertheless, highly reflective targets can cause errors on account of the glare caused by the strong reflections. If this happens, a less reflective surface should be used. The ideal target is white, slightly shiny and with a smooth surface, see [Chap. A 1](#), item ILR-TB3800.

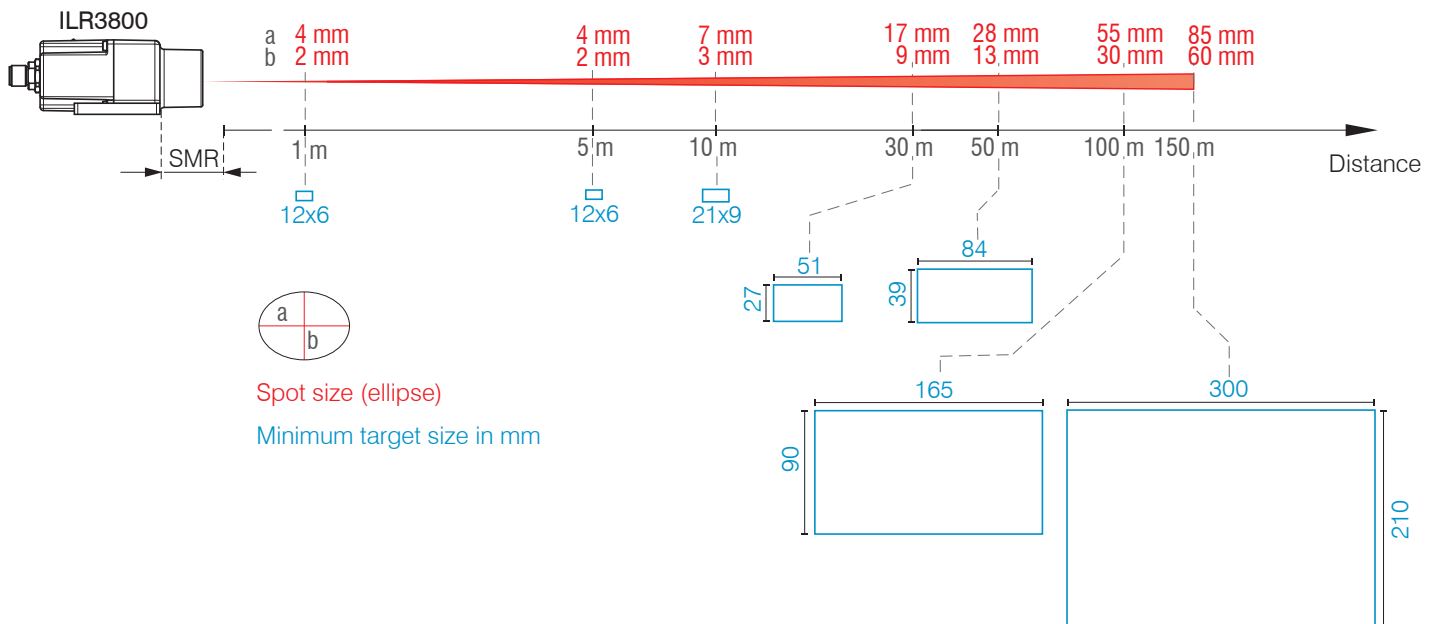
If ambient light is directly incident into the sensor or onto the target, these areas should be shielded.

5.1.3.2 Thermal influences

When the sensor is commissioned, a warm-up time of at least 5 minutes is required to achieve uniform temperature distribution in the sensor.

Rapid temperature changes are not detected immediately due to the damping effect of the sensor's heat capacity.

5.1.3.3 Mechanical vibrations

If a high degree of accuracy or a long range is required, the sensor and target must be mounted on a stable surface that is damped against vibrations.

5.1.3.4 Motion blur

Uniform relative movement up to 1.6 m/s is possible without dropouts. Targets that move faster or that are not very reflective can cause motion blurring.

5.1.3.5 Angular influences

In principle, angular behavior during laser distance measurement is also affected by the reflective properties of the target surface. Tilt angles of the measuring object with diffuse reflection are possible up to 30° without stronger influences. With very weak reflection, e.g. with coarse-pored or dark surfaces, an angle of 5° and higher is disturbing. With reflective surfaces, the angle must be kept as small as possible, but must not be 0°, as the direct reflection into the receiver can cause damage to sensor components.

5.2 Mechanical fastening

5.2.1 Sensor mounting

i Ensure careful handling of the sensor during installation and operation.

▶ Mount the sensor on the sensor base plate using four M4 screws.

Optionally, 4 set screws can be used to adjust the sensor.

A visible laser beam helps to align the sensor with the target object. Please also refer to the notes for operation, see [Chap. 5.1](#), when aligning the sensor.

If the laser beam does not strike the object surface at a perpendicular angle, measurements might be inaccurate.

Through-bolt connection 1				
Through-bolt length	Screw-in depth	Number	Screw	Torque
6.5 mm	Min. 10 mm	4	M4 ISO 4762-A2	1.7 N·m for strength class 70 2.3 N·m for strength class 80

Abb. 6 Mounting conditions

i Mount the sensor only to the existing through-bores on a flat surface. Any type of clamping is not permitted.
Never exceed the specified torques.



Abb. 7 Dimensional drawing optoNCDT ILR3800-100, dimensions in mm

i Position the sensor so that the connections and LED elements are not concealed.

1) Recommendation: Test under use conditions!

5.2.2 Start of measuring range

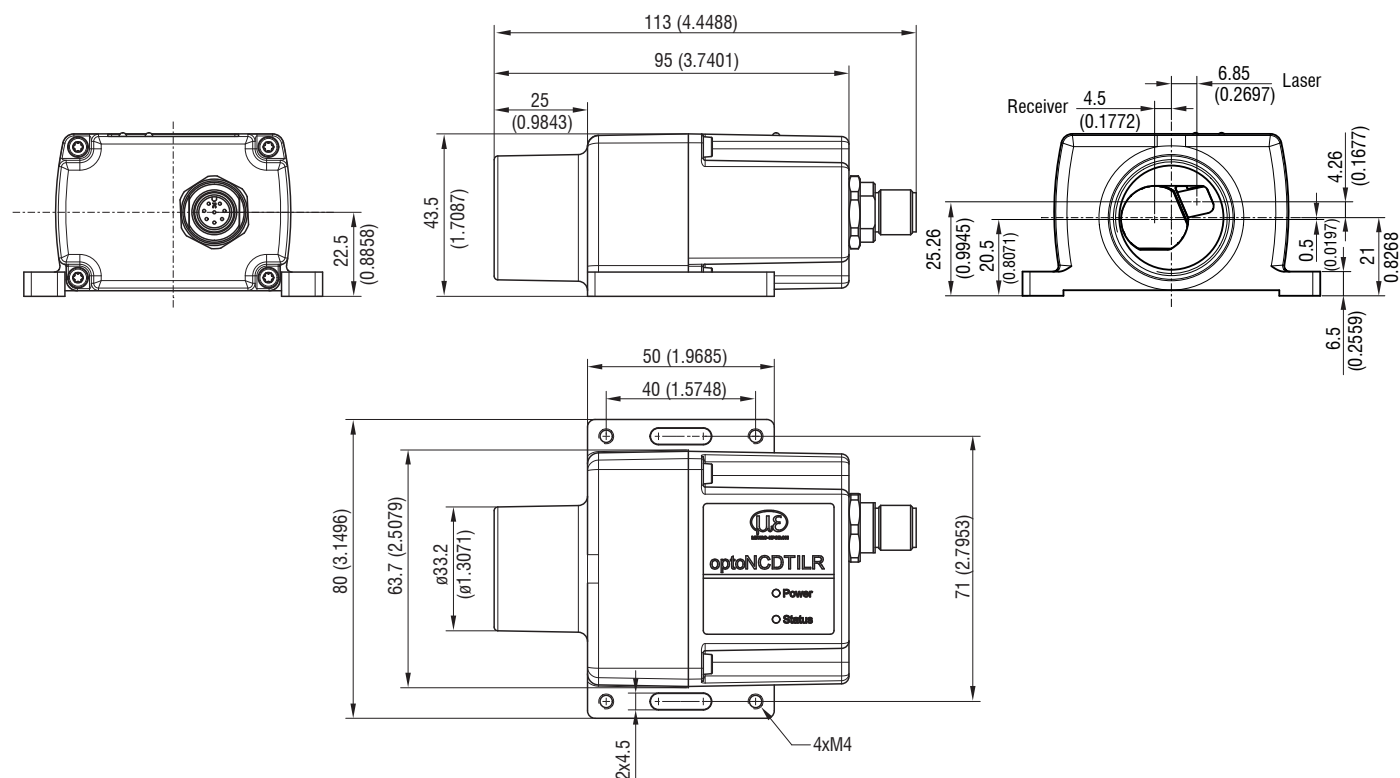
The ILR3800 series sensors are calibrated to a zero point within the sensor. The measurement begins with an offset of 0.05 m from this zero point. If the measuring object is either within this 0.05 m range or beyond the maximum distance (100 m for diffusely reflecting objects, 150 m with a reflective foil), then it is outside the measuring range. In this case, an error is output.

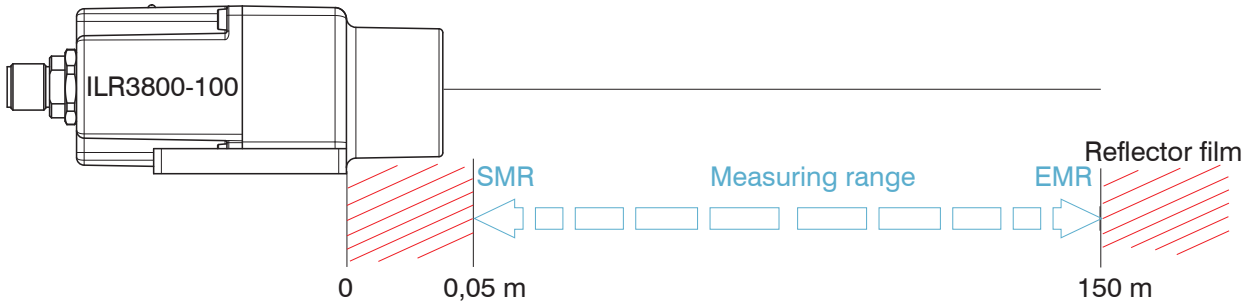

SMR: Start of measuring range

EMR: End of measuring range

Failure; outside the measuring range

Abb. 8 Offset of 0.05 from the sensor's zero point.

5.2.3 Reflector setup

The sensor measures the distance to moving and stationary objects:

- In a range of 0.05 m ... 100 m on diffusely reflecting surfaces
- Between 35 and 150 m onto reflectors (e.g. ILR-RF210, Scotchlight by 3M etc.)

The measurement laser can be used for alignment. When aligning the sensor, proceed as follows:

- ➔ Position the sensor at least 35 m away from the reflector.

NOTICE

When measuring on reflectors or reflective surfaces, keep a distance of at least 35 m to avoid damage to sensor components caused by the reflected light. The visible point of light of the measurement laser should be in the center of the reflector.

- ➔ Check that the measurement laser is pointing at the center of the reflector and adjust if necessary.

The laser spot must be in the center of the reflector over the entire measuring range.

Target (reflector) and sensor can only be tilted by at most 5° relative to one another.

5.2.4 Vertical and horizontal laser line correction

The laser module is subject to manufacturing tolerances. Consequently, the laser exit axis may deviate <math><0.2^\circ</math> from the sensor axis. If necessary, extremely precise adjustment can be performed using the optionally available ILR-MP3800 mounting plate, see [Chap. A 2](#).



Abb. 9 Manufacturing tolerance laser exit versus sensor axis

Correction

- ▶ Maximize the distance between the sensor and the measuring object/reflector.
- ▶ Loosen the mounting screws in the slots.

Vertical correction of the laser exit

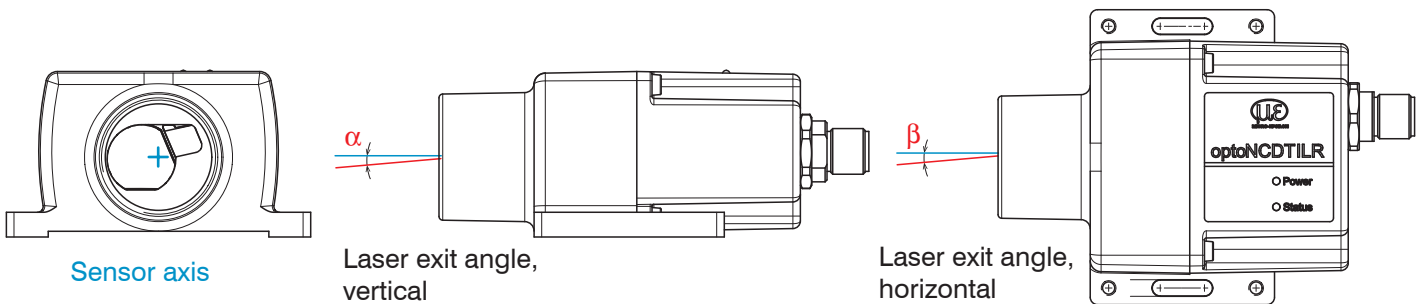
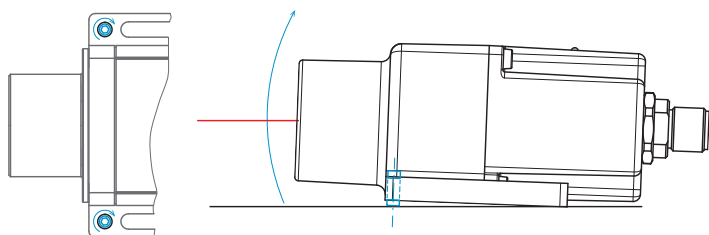

- ▶ Screw the included set screws into the mounting holes.
- This raises/lowers the laser exit.

Horizontal correction of the laser exit

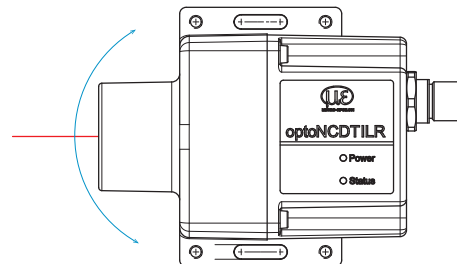

- ▶ Turn the sensor.
- Normally the slots are sufficiently large for the horizontal correction of the laser exit.

- ▶ Tilt or turn the sensor until the laser beam hits the measuring object/reflector in the center.
- ▶ Tighten the mounting screws in the slots.

5.3 Indicator elements

LED	Function	Indicator	Status
Status	Reflection intensity	Green	Signal very good
		Yellow	Signal satisfactory
		Red	Weak signal ¹ /error
Power	Operational readiness	Off	No supply voltage
		Green	Ready for operation
		Yellow	Warm-up time ²



LED Status

LED Power

The *Status* LED indicates the reflection intensity of a measurement. This LED generally lights up when a measurement is started. If the *Power* indicator turns red and the *Status* indicator turns yellow at the same time, a boot error has occurred. Recovery is necessary.

- 1) Reduced measurement accuracy and measurement frequency possible
- 2) Only for ILR3800-100-H series sensors with an integrated heating element

5.4 Electrical connections ILR3800-100

5.4.1 Connection possibilities

Source Cable/power supply Interface Terminal



Abb. 10 Connection examples on ILR3800

The various peripheral devices can be connected to the sensor.

The IF2001/USB, IF2004/USB, IF2008/ETH and DPU converters also provide the sensor's supply voltage (24 V DC).

The IF2035/PROFINET, IF2035/EIP, and IF2035/EtherCAT interface modules also supply the sensor with power (24 V DC).

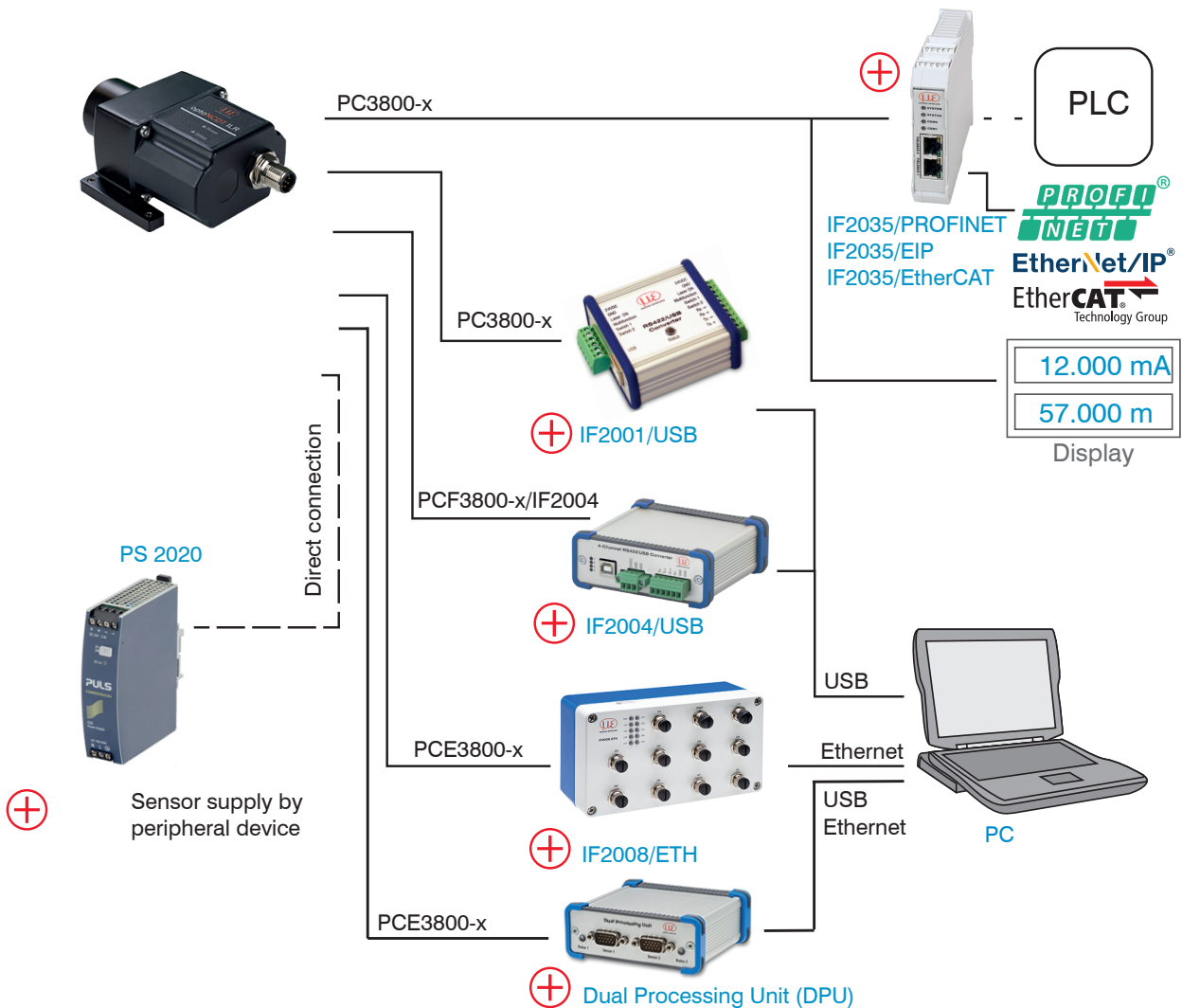
The voltage supply for the converters and the interface modules is provided, for example, by the optionally available PS 2020 power supply.

5.4.2 Pin assignment

The plug connection is located on the back of the sensor. It is a 723 series 8-pin circular connector (flange plug) from the company Binder.

This plug connector ensures optimum shielding as well as a high IP protection class. You will need a corresponding cable socket with a shielding ring as the counterpart.

PC3800 cables with open ends and finished in various ways are optionally available, see [Chap. A 1](#). The optionally available PC3800-x and PC3800/90-x supply/output cables can be used with drag chains and have the following bend radii:

- 47 mm (once)
- 116 mm (permanent)

NOTICE

Make sure that cable ends are not exposed. This could cause short circuits. Connecting input signals to outputs can damage the sensor!

Signal Sensor	PC3800-x			Comments, circuitry
	Pin	Wire color	Explanation	
RX+	1	white	RS422 input (symmetrical)	Internally terminated with 120 ohms
RX-	2	brown		
Multifunction input	3	green	Multifunction input (trigger, zero/master)	Trigger input, $t_i > 2$ ms
IOUT	4	yellow	Analog output	4 ... 20 mA
TX -	5	gray	RS422 output (symmetrical)	Receiver terminated with 120 ohms
TX+	6	Pink		
GND	7	blue	Ground	Reference potential for supply and analog output
+U _B	8	red	Supply 24 V	10 ... 30 VDC, typ. 24 VDC

Abb. 11 Pin assignment for power supply and signal, 8-pin plug connector

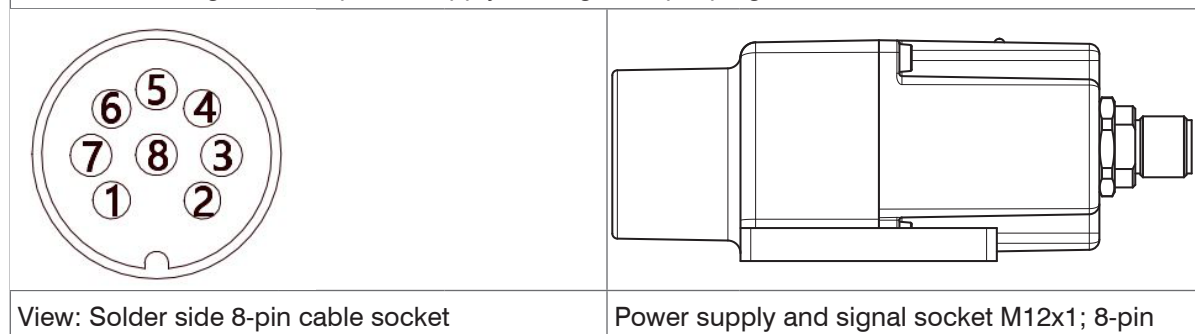

The ground lines are connected internally and are the reference potential for all voltage values given below. The limit values for the voltages, loads and logic level comply with RS422 standards. All outputs are designed to be permanently resistant to short circuits.

5.4.3 Supply voltage

Rated voltage 24 VDC (10 ... 30 V), power < 5.5 W (measurement mode active), heater model 24 ... 30 V

➤ Only turn on the power supply after wiring has been completed.

➤ Connect the G (red) and L (red/blue) inputs on the sensor to a 24 V voltage supply.



Abb. 12 Supply voltage connection

Voltage supply only for measuring devices, not to be used for drives or similar sources of impulse interference at the same time.

MICRO-EPSILON recommends using the optionally available PS2020 power supply unit, see [Chap. A 1](#), for the sensor.

5.4.4 Analog output

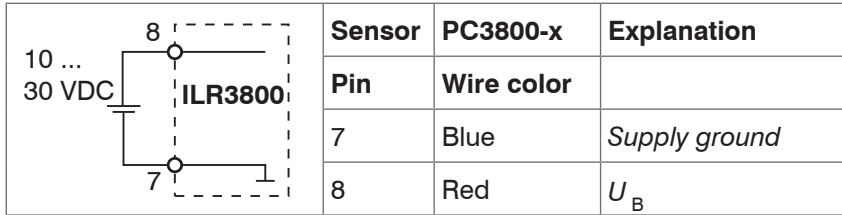
The sensor provides a current output of 4 ... 20 mA

• The output may not be used continuously in short-circuit operation without a load resistor.

i Continuous short-circuit operation leads to thermal overloading and thus causes the output to switch off automatically.

➤ Connect the 4 (yellow) and 7 (blue) inputs on the sensor to a measuring device.



Abb. 13 Analog output switching

Analog output properties		
- 4 ... 20 mA	- Behavior when error reported: 3 mA	Load $R_B < U_B - 1 \text{ V} / 20 \text{ mA}$ @10 V: $R_B < 450 \text{ ohm}$ @24 V: $R_B < 1150 \text{ ohm}$ @30 V: $R_B < 1450 \text{ ohm}$
- R_i 30 ohm	- Accuracy: 0.1 % FSO	
- Distance range limits adjustable	- Short circuit proof	
- Resolution: 16-bit DA converter		

The current impressed in the line is proportional to the measured distance. You can find more details on this in the Analog output section, see [Chap. 6.7](#).

i The measured values are always output via the analog output.

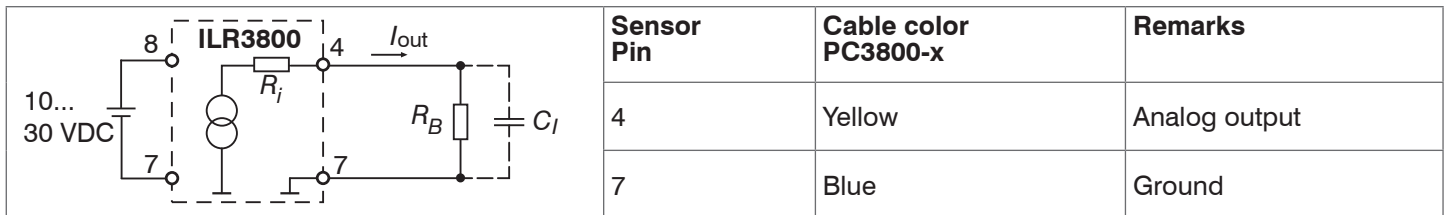
5.4.5 RS422 (with IF2001/USB converter)

The RS422 interface can be used for configuration as well as for permanent data transmission, even over longer distances. It is interference-resistant and suitable for industrial applications. Distances of up to 1200 m are possible with a twisted-pair cable.

For the connection between sensor and PC, the lines must be crossed.

i Only disconnect or connect the sub-D connection between the RS422 and USB converter when no voltage is flowing.

Characteristics

- Maximum input voltage RX+, RX- : $\pm 14 V_{max}$ internally terminated with 120 ohms.
- Output voltage TX: $\pm 2 V$, differential at 2×50 ohms

Parameters

- Baud rate 115200 baud
- Data bits: 8
- Parity: None
- Start/stop bit: 1
- Handshake: No
- Command protocol: ASCII

i The RS422 interface is widely used in industrial applications. Use a suitable USB converter, e.g. the IF2001/USB, see [Chap. A 1](#), if your PC/Notebook only has USB ports.

Sensor			Terminal, PLC, IF2001/USB converter from MICRO-EPSILON
Pin	Cable color (Cable: PC3800-x)	Function	Function
1	White	Rx+	Tx+
2	Brown	Rx-	Tx-
5	Gray	Tx-	Rx-
6	Pink	Tx+	Rx+
7	Blue	GND	GND

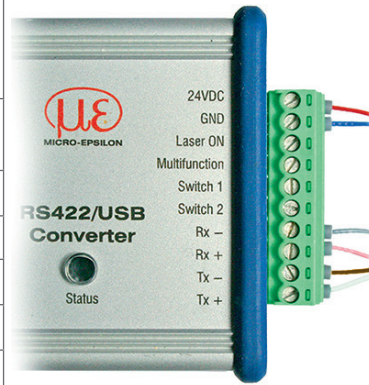

Symmetrical differential signals according to EIA-422, not electrically separated from the voltage supply.

Use a shielded cable with twisted wires, e.g. PC3800-x.

Abb. 14 Crossed data lines on receive and transmit side

5.4.6 Multifunction input

The multifunction input enables the triggering, data acquisition/data output and zeroing/mastering. The function depends on the programming of the input and on the timing of the input signal.

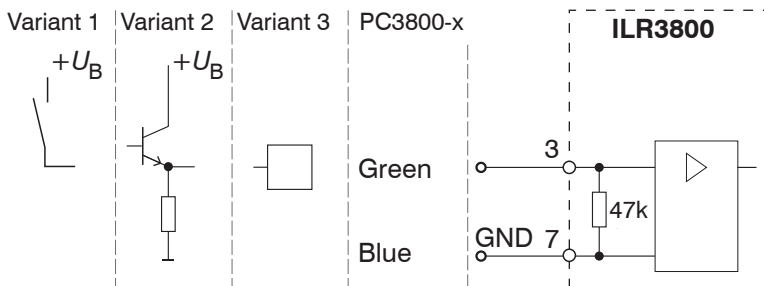

Trigger pulse: > 2 ms
 High approx. $2/3 * +U_B$
 Low approx. $1/3 * +U_B$
 Internal pull-down resistor, an open input is detected as Low.
 Connect the input to $+U_B$ in order to trigger the function.

Abb. 15 Basic circuit for triggering

5.4.7 Triggering

Configure the desired triggering behavior

- with the sensorTOOL program
- or using ASCII commands (e.g. TRIGGER and TRIGGERLEVEL), see [Chap. A 4.3.10](#).

The number of measured values received can be specified on the ILR3800 after a trigger pulse.

You can start level triggering with

- $+U_B$ at the trigger input for H-level triggering
- 0 V at the trigger input for L-level triggering

5.5 Electrical connections ILR3800-100-IO

5.5.1 Connection possibilities



Abb. 16 ILR3800-100-IO connection example

The IO-Link master also supplies the supply voltage (24 V DC) to the sensor.

5.5.2 Pin assignment

The plug connection is located on the back of the sensor. It is a 4-pin M12 circular connector (flange plug). This plug connector ensures optimum shielding as well as a high IP protection class. You will need a corresponding cable socket with a shielding ring as the counterpart.

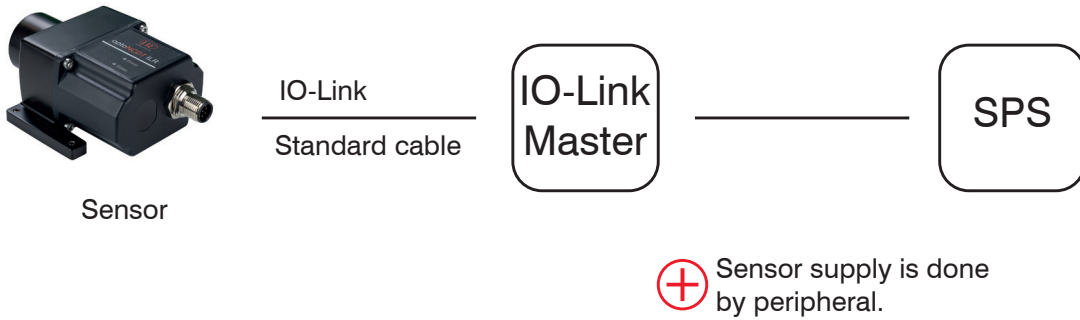
Sensor signal	Explanation	PC3800-x IO-Link	
		Pin	Wire color
+UB	Supply voltage 10 ... 30 VDC, typ. 24 VDC	1	Brown
C/Q	Standard Input/Output	4	Black
GND	Supply ground	3	Blue
		<p>View: Solder side 5-pin M12 cable connector</p>	

Abb. 17 Pin assignment for power supply and signal

5.5.3 Supply voltage

Nominal value 24 VDC (10 ... 30 V, $P < 4$ W)

The ILR3800-100-IO sensor is supplied via the IO-Link master.

- ▶ Only turn on the power supply after wiring has been completed.
- ▶ Alternatively, connect the 4 (brown) and 7 (blue) inputs on the sensor to a 24 V power supply.



Abb. 18 Supply voltage connection

Voltage supply only for measuring devices, not to be used for drives or similar sources of impulse interference at the same time.

Micro-Epsilon recommends using the optionally available PS2020 power supply unit, see [Chap. A 1](#), for the sensor.

6. Operation ILR3800-100

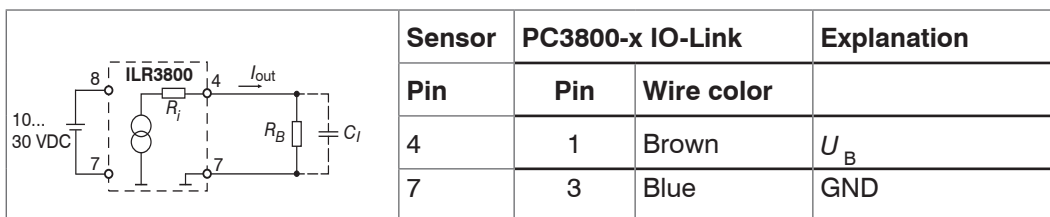
6.1 Getting ready for operation

- Mount the ILR3800 sensor according to the installation instructions, see [Chap. 5.1](#).
- Connect the sensor to downstream display or monitoring units and the power supply.

NOTICE

The sensor may only be connected to peripherals when it does not carry power, that is, only when the supply voltage has been switched off.

The measurement laser starts when the supply voltage is applied if an active measurement (see `LASER MEASURE`) has previously been saved in the sensor.

The sensor is ready to use after approx. 2 s, digital accuracy is immediate. The sensor typically requires a warm-up time of 5 min for reproducible measurements via the analog output.

- The sensor can be put in an Autostart state. To do this, all desired parameters must be set and saved on the sensor. If the sensor is then switched off during an active measurement, it immediately resumes the saved measurement task once the power supply is connected again.

If the `POWER` LED is off, no power is being supplied.

6.2 Operation using sensorTOOL

The sensor must be connected to a PC/Notebook via an RS422 converter and the supply voltage must be applied.

The sensorTOOL program also finds connected sensors via a network. You can find this program online at <https://www.micro-epsilon.de/download/software/sensorTOOL.exe>.

- Launch the sensorTOOL program and click on the  button.

The program will now search for connected ILR3800 sensors on the available interfaces.

- Select a desired sensor. Click the `Start Data Acquisition` button.



Abb. 19 Auxiliary sensor search program



Abb. 20 Measurement view in the sensorTOOL program

➡ Switch to the Settings tab.
Here you can access features such as triggering and analog output.

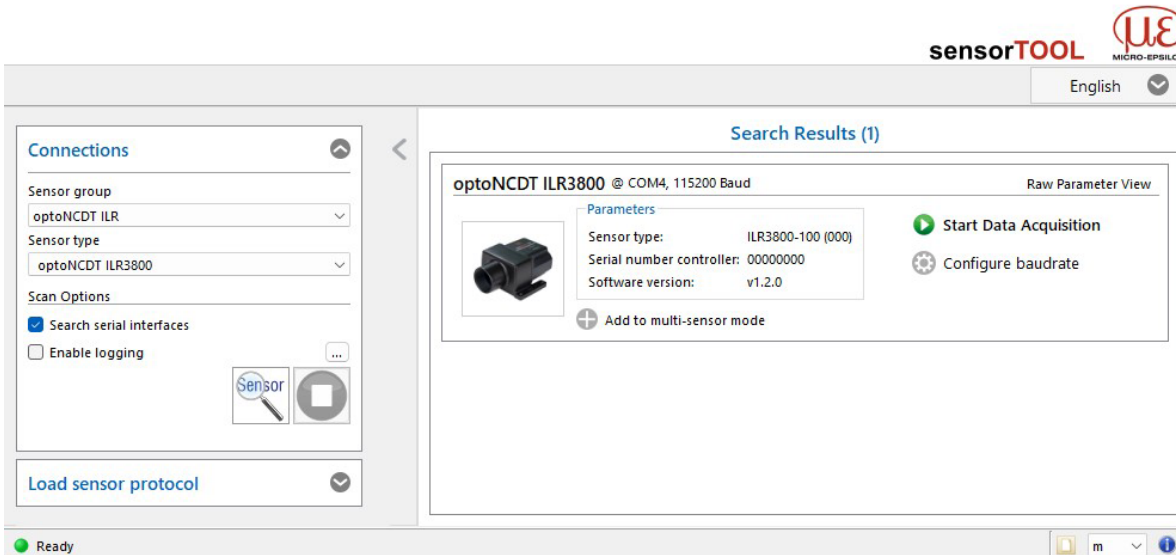

Abb. 21 Settings tab in the sensorTOOL program
optoNCDT ILR3800

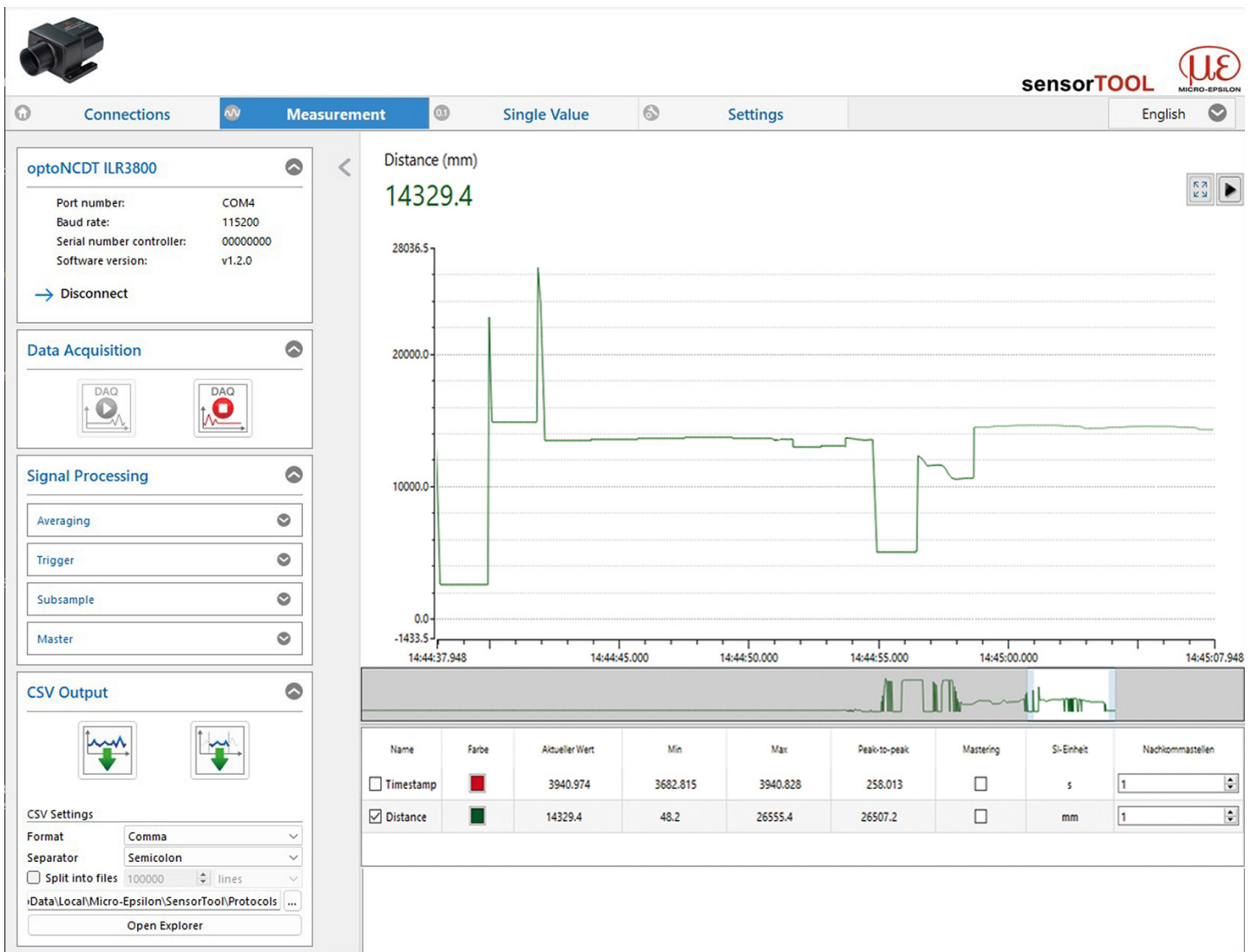
6.3 Data acquisition, presets

By selecting a measurement mode in the Data Acquisition section, you can switch between the saved configurations (presets) for various target surfaces and target movement speeds. Selecting a target activates a predefined configuration of settings that will produce the best results for the material selected.

Data acquisition	Automatic	Recommended for measurements on poorly reflective or dark targets. The measuring rate depends on the reflectance of the target. The measuring rate is typically in the range of 3 ... 20 Hz.
	High speed	Suitable for fast measurements on moving objects and quick distance jumps. The target movement speed is typically up to 1.6 m/s. The measured values are output at 20 Hz.
	Accurate	Preset for high accuracy and tolerance in the event of distance changes. The measuring rate depends on the reflectance of the target. The measuring rate is typically in the range of 3 ... 20 Hz.
	Precise	Preset for highest precision. Provides precise distance measurements on highly reflective targets such as target plate/reflector. Not recommended for moving or poorly reflecting targets. The measured values are output at 20 Hz.
	Dynamic	Preset for dynamic measurements. Reacts particularly quickly to sudden changes in distance. Optimizes the sensor settings for a high reaction speed in order to detect fast movements precisely.

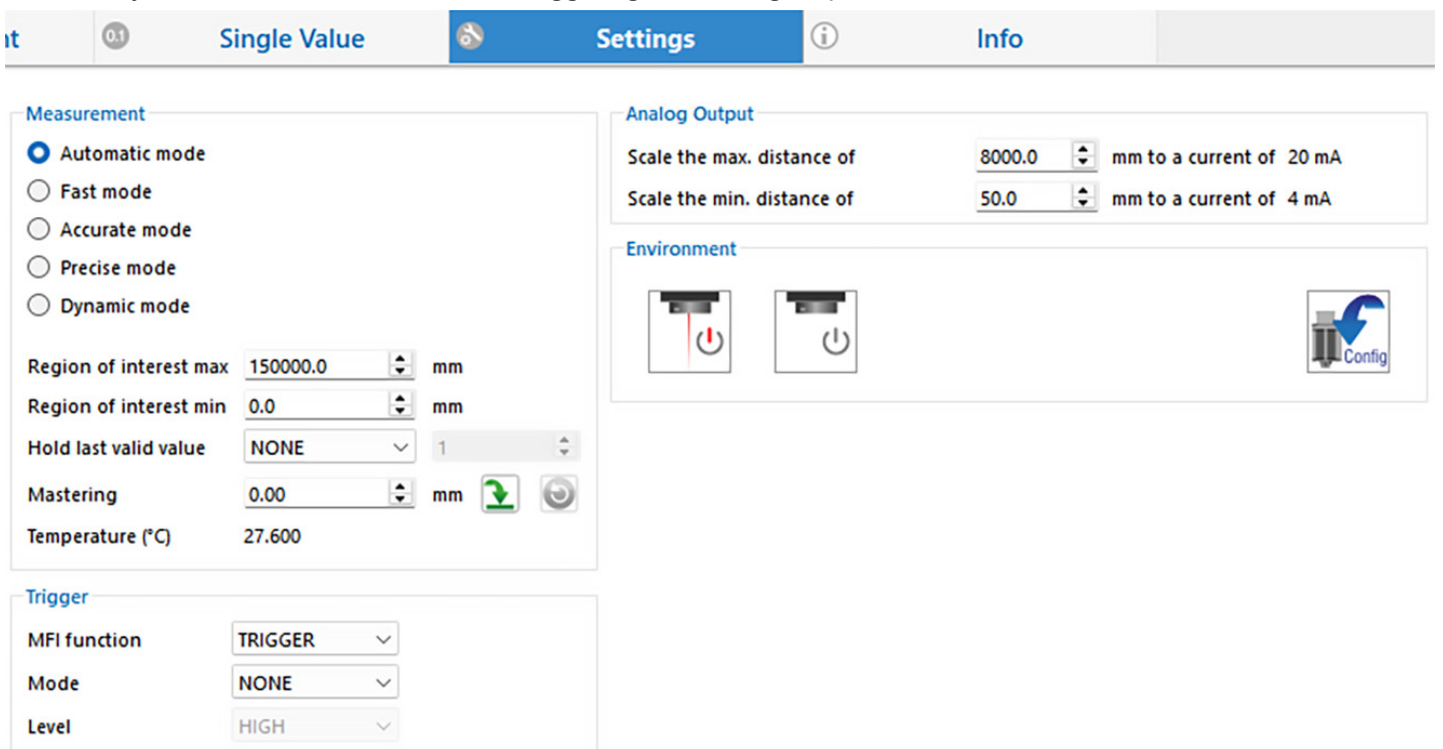

Fields with gray background require a selection.



value

Fields with dark border require entry of a value.

➡ Switch to the Settings > Data acquisition menu and select the desired measurement mode.



Abb. 22 Data acquisition menu, for selecting measurement mode, etc.

6.4 Masking the region of interest, ROI

Masking defines the ROI (region of interest) for the distance calculation. This function is used, for example, to suppress interfering reflections.

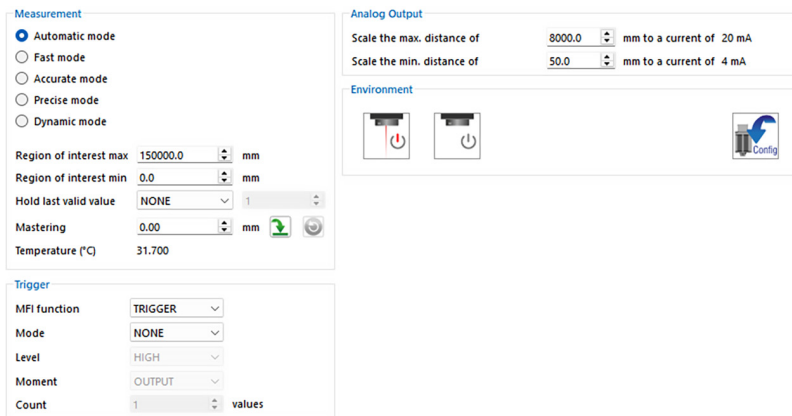

Abb. 23 Light blue areas limit the region of interest

➡ Switch to the Settings > Data acquisition menu and set the values for Region of interest min and Region of interest max.

- The value ranges for the parameters
- upper and lower limit (digital outputs),
 - analog output scaling,
- must be within the region of interest.

6.5 Triggering

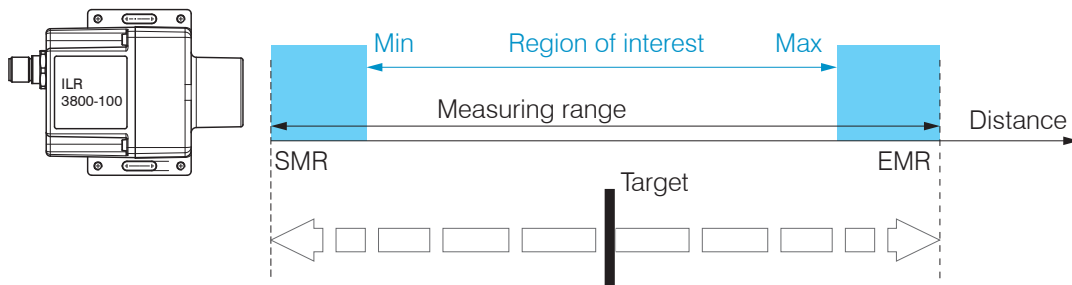
6.5.1 General

The acquisition and output of measured values by the ILR3800 can be controlled using an external electrical trigger signal or commands. Digital outputs are affected by this. The measured value at the time of the trigger event is output with a delay, see [Chap. 6.5](#).

- Triggering has no effect on the preselected measuring rate or on the time response, and therefore there are always 4 cycles + 1 cycle (jitter) between the trigger event (level change) and the start of the output.
- The TRIG input is used as the external trigger input.
- Factory setting: no triggering, the sensor starts with the measured value output immediately after being switched on.
- The pulse duration of the “Trigger in” signal is at least 2 ms.

The triggering of the measured value acquisition and output have the same time response.

➡ Switch to the **Settings > Trigger** menu and select the desired triggering conditions.

The screenshot shows a 'Trigger' menu with the following settings:

- MFI function: NONE
- Mode: NONE
- Level: HIGH
- Moment: OUTPUT
- Count: 1 values

Abb. 24 Triggering menu

MFI function	None / Master / Trigger	None = MFI inactive; Master = MFI initiates mastering; Trigger = MFI starts data acquisition/data output depending on the current setting of Moment
Mode	None / Edge / Pulse / Software	Selection for the desired type of triggering. None = no triggering, continuous output of measured values; Edge = edge triggering; pulse = level triggering or pure software triggering
Level	High / Low	With edge triggering and High: rising edge With edge triggering and Low: falling edge
Moment	Input / Output ¹	Defines type of triggering Input = data acquisition, output = data output
Number	value	For edge and software triggering, the number of measured values to be output must be specified.

The following applies for triggering: $f_T < f_M$

f_T Trigger frequency

f_M Measuring rate

1) Input: The laser must be switched off manually (Laser off). The laser is then activated via a trigger and a measurement is started.

Output: The laser must be switched on manually (Laser measure). The output of measured values is activated via a trigger.

Fields with gray background require a selection. value Fields with dark border require entry of a value.

The following are used as triggering conditions:

Level triggering with high level / low level.

Continuous measured value acquisition/output as long as the selected level is present. Afterwards, the data acquisition/output stops.

The pulse duration must be at least as long as one cycle. The subsequent pause must also be at least as long as one cycle.

U_1 = Trigger signal

W = Displacement signal



Abb. 25 High trigger level (top) with analog output A_0 and RS422 output signal D_0 (bottom)

Edge triggering with rising or falling edge.

Starts the measured value acquisition as soon as the selected edge is detected at the trigger input. The sensor outputs the specified number of measured values when the triggering condition is met.

Value range from 1 ... 2,147,483,646.

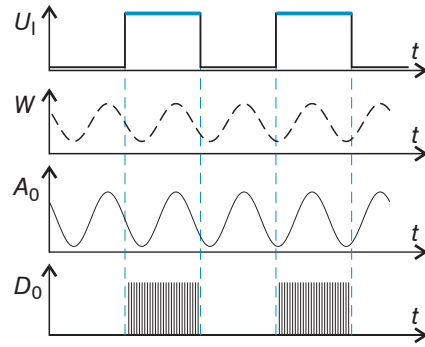
The pulse duration must be at least 2 ms.



Abb. 26 HL trigger edge (top) with analog output A_0 and RS422 output signal D_0 (bottom)

Software triggering. The measured value acquisition is triggered by the command TRIGGERSW. After the trigger event, the sensor outputs the previously defined number of measured values or starts continuous measured value output. The measured value output can also be stopped using a command.

6.5.2 Triggering data acquisition

Measured value acquisition triggering processes measurements that are taken after the trigger event. Previously acquired measured values are discarded. Acquisition triggering therefore has a direct impact on the further processing of measured values. The sensor corrects errors internally based on the settings in the saved configurations. In the case of moving targets and data acquisition triggering, Micro-Epsilon recommends the Auto and Fast modes.

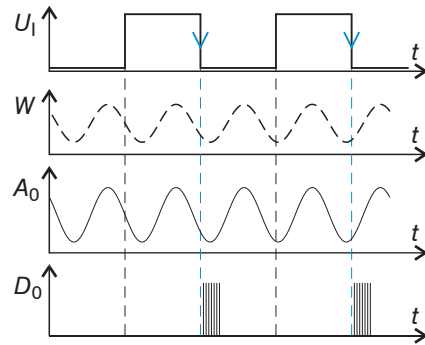
6.5.3 Triggering measured value output

The measured values are computed continuously and independently of the trigger event. A trigger event merely triggers output of the values via the RS422 interface.

- Acquisition triggering requires data acquisition to be active in the sensor.

6.6 Mastering

Use zeroing and mastering to define a nominal value within the measuring range. This shifts the output range. This feature can be useful, for example, when several sensors carry out measurements simultaneously in thickness and planarity measurements.

Zeroing/ Mastering	inactive	<i>Normal measurement value or zeroing/mastering is reversed.</i>	
	active	value	<i>Specification, e.g. of the thickness of a master piece. Range of values 0 to max. + 2 x measuring range</i>



Fields with gray background require a selection.

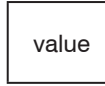

value

Fields with dark border require entry of a value.

Mastering is used to compensate for mechanical tolerances in the sensor measurement setup or to correct chronological (thermal) changes to the measuring system. The master value, also called calibration value, is defined as the nominal value.

The measured value provided at the sensor output when measuring a master object is the "Master value". Zeroing is a special feature of mastering, since the master value is "0" here.

During mastering, the sensor characteristic is moved in parallel. Moving the characteristic reduces the relevant measuring range of a sensor (the further master value and master position are located, the greater the reduction).

Mastering / zeroing sequence:

- Bring the measuring object and sensor into the desired relative position.
- Send the master command.

The MASTER command waits a maximum of 2 seconds for the next measured value and uses it for mastering. If no value is measured within this time, e.g. in case of external triggering, the command returns with the error E220 Timeout.

After setting the master, the sensor will issue new readings that relate to the master value. By resetting with the `Inactive` button, the status before mastering is restored.

- Mastering or Zeroing requires a target object to be present in the measuring range.
- ! Mastering and Zeroing influence the digital and the analog output.

An invalid master value, e.g. no peak present, is acknowledged with the Error E602 Master value is out of range.

6.7 Analog output

6.7.1 Scaling

The distance value is output via the analog output. The resolution of the analog output is 16 bit.

Output range	4 ... 20 mA, error value approx. 3 mA		
Scaling	Standard scaling	Scaling to 50 ... 8000 mm	
	Two-point scaling	Min. distance (in mm):	<i>value</i>
		Max. distance (in mm):	<i>value</i>

The following applies to two-point scaling:

- min distance < max distance

The value `min distance` corresponds to the new start of the measuring range, the value `max distance` corresponds to the new end of the measuring range. Two-point scaling allows for user-defined specification of the measuring range to be output.

Fields with gray background require a selection. value Fields with dark border require entry of a value.



Abb. 27 Scaling the analog signal

6.7.2 Calculation of the measured value from the current output

Current output

Variables	Value range	Formula
I_{OUT} Current in mA	[4; 20] Measuring range	$d = \frac{(I_{OUT} - 4)}{16} * MB$
MR Measuring range in mm	{150000} ¹	
d Distance in mm		

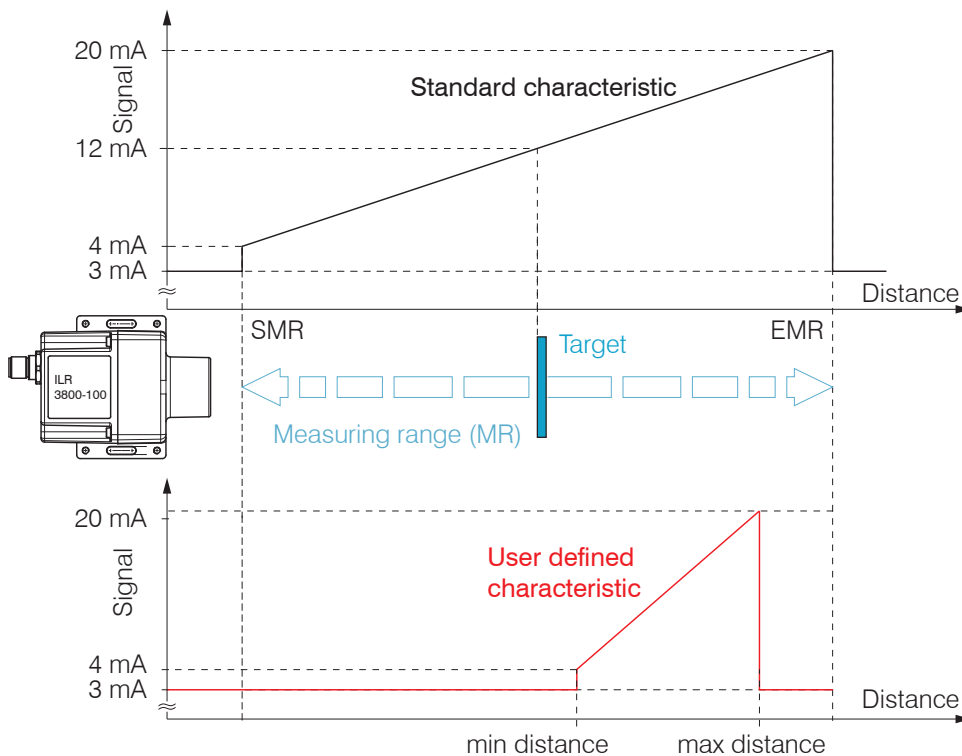
Current output with scaling

Variables	Value range	Formula
I_{OUT} Current in mA	[4; 20] Measuring range	$d = \frac{(I_{OUT} - 4)}{16} * n - m $
MR Measuring range in mm	{150000} ¹	
m, n Teach range in mm	[0; MR]	
d Distance in mm	[m; n]	



1) The actual value for the measuring range depends, inter alia, on the reflectivity of the target and on whether a reflector film is used.

6.8 Measurement hold mode, error handling

The error handling function regulates the behavior of the analog output and RS422 interface in the event of an error.

Error handling	None	The analog output delivers approx. 3 mA instead of the measured value. The RS422 interface outputs an error value.	
	Infinite	The analog output and RS422 interface remain on the last valid value.	
	Count	value	Value range [1 ... 2147483645], last value held for n cycles, then an error value is output.

If no valid measured value can be determined, an error is output. Alternatively, if this interferes with further processing, the last valid value can be held, i.e. output repeatedly, for a certain amount of time. After the selected number of cycles have elapsed, an error value is output.

 Fields with gray background require a selection.  value Fields with dark border require entry of a value.

6.9 System settings

6.9.1 Saving the settings

After programming, save all settings permanently so that they will be available again the next time you switch on the sensor.

➤ Switch to the Settings > Environment menu and click on the  button.

It is also possible to switch the laser on and off here.

Laser On (factory setting, menu field on the left): measurement is started.

Laser Off: laser is switched off, no measurement possible.



Abb. 28 Settings menu with the Save button

6.9.2 Language

The following languages are available in the sensorTOOL:

- German
- English
- Chinese
- Korean
- Japanese.

➤ Switch the language in the menu bar.



Abb. 29 Language selection in the menu bar

6.10 ILR3800-100-H with heating element

The ILR3800-100-H sensor contains a heating element. This enables an extended operating temperature range from -40 °C to +50 °C. If the sensor is started below 0 °C, the internal heating automatically warms up the sensor to the required working temperature. During the warm-up phase, measurement is not possible. The measuring laser is off and the Power LED lights up yellow.

After the heating phase is finished, the sensor switches to the measurement operation mode. The Power LED lights up green. The measuring laser is started depending on the measurement setting.

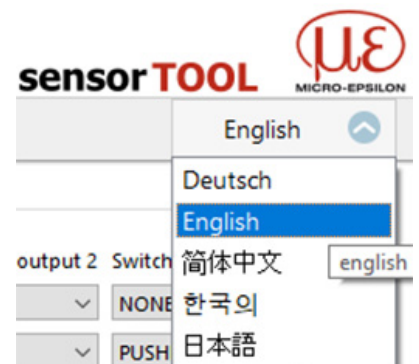
7. Operation ILR3800-100-IO

7.1 Getting ready for operation

- ▶ Mount the ILR3800 sensor according to the installation instructions, see [Chap. 5.1](#).
- ▶ Connect the sensor to downstream display or monitoring units and the power supply.

NOTICE

The sensor may only be connected to peripherals when it does not carry power, that is, only when the supply voltage has been switched off.

The measurement laser starts when the supply voltage is applied if an active measurement (see `LASER MEASURE ON`) has previously been saved in the sensor.

The sensor is ready to use after approx. 2 s, digital accuracy is immediate.

- The sensor can be put in an Autostart state. To do this, all desired parameters must be set and saved on the sensor. If the sensor is then switched off during an active measurement, it immediately resumes the saved measurement task once the power supply is connected again.

If the `POWER` LED is off, no power is being supplied.

7.2 Operation using IO-Link

The sensor exchanges process data and parameters via IO-Link. For this purpose, connect the sensor with a suitable IO-Link master.

IO-Link specification	V 1.1
Minimum cycle time	4.0 ms (COM2)
Transmission speed	COM2 (38.4 kBaud)
Process data width	32 bit output (from device to master)
Process data type	Mixed (27 bit integer + 3 Boolean)
Parameterization server function (data storage)	Yes

Abb. 30 IO-Link interface properties

7.3 Process data

The factory settings ensure that the process data telegram of the sensor receives the measured distance value. The distance value is output in tenths of a millimeter (27-bit signed integer). In addition, the logical state of the three switching outputs is transmitted by the last three bits.

Bit 0 – bit 26	Measurement value
Bit 29	ErrorOut3 (switching output 3)
Bit 30	ErrorOut2 (switching output 2)
Bit 31	ErrorOut1 (switching output 1)

Abb. 31 Factory-set process data format

7.4 Device data

The device data include

- parameters,
- identification data and
- diagnosis data.

This information can be transmitted to or from the sensor in parallel with the process data. For this purpose, the IO-Link master requires a sensor-specific device description file (IODD).

The current device description file is available at:

<https://www.micro-epsilon.com/distance-sensors/laser-distance-sensors/optoncdt-ilor3800/?sLang=en>

8. Digital interface RS422

8.1 Preliminary remarks

This function is only available in conjunction with the ILR3800-100 sensor.

The RS422 interface has a maximum baud rate of 230400 baud. The baud rate is set to 115200 as default. The measuring rate is at most 20 Hz.

Data format: Binary format for measured values, commands as ASCII character string

Interface parameters: 8 data bits, no parity, one stop bit (8N1)

i Only disconnect or connect the sub-D connection between the RS422 and USB converter when no voltage is flowing.

8.2 Measurement data format

For the ILR3800:

- Transmission is always done in complete data frames, the format does not change.
- Each data frame consists of the timestamp in ms and the distance in 1/10 mm, followed by a footer byte.
- Each value is transmitted in 4 bytes; the lower 7 bits of a byte are used.
- The 4*7 bits are combined into a 28 bit value.
- The top bit 7 of a byte is coded as follows:
 - 1 Another byte or other bytes follow,
 - 0 Last byte of the value.
- The bytes are transferred from the sensor to the PC in little-endian format. For ease of reading, however, we use big endian in the following.

Each data frame consists of two or three signals/values (see also the OUTADD_RS422 command) in the following order: **TIMESTAMP | TEMPERATURE | DISTANCE**.

Description	Bit 7 (order bit)	Bit 6	Bit 5	Bit 4	Bit 3	Bit 2	Bit 1	Bit 0
LSB Timestamp	1	D6	D5	D4	D3	D2	D1	D0
	1	D13	D12	D11	D10	D9	D8	D7
	1	D20	D19	D18	D17	D16	D15	D14
MSB Timestamp	0	D27	D26	D25	D24	D23	D22	D21
LSB Distance	1	D6	D5	D4	D3	D2	D1	D0
	1	D13	D12	D11	D10	D9	D8	D7
	1	D20	D19	D18	D17	D16	D15	D14
MSB Distance	0	D27	D26	D25	D24	D23	D22	D21
Footer	0	0	0	1	Change	0	0	Overflow

Abb. 32 Structure of measurement data frame with two data values and footer byte

- Change bit: Always 0 for the ILR3800.
- Overflow: Always 0 with the ILR3800.

Example

LSB	1	D6	D5	D4	D3	D2	D1	D0
	1	D13	D12	D11	D10	D9	D8	D7
	1	D20	D19	D18	D17	D16	D15	D14
MSB	0	D27	D26	D25	D24	D23	D22	D21

After combining the 28 bits and transferring them to an unsigned integer with 32 bits, the uppermost bits not used by the sensor are set to 0:

0	0	0	0	D27	D26	D25	D24
D23	D22	D21	D20	D19	D18	D17	D16
D15	D14	D13	D12	D11	D10	D9	D8
D7	D6	D5	D4	D3	D2	D1	D0

Abb. 33 Distance bytes in the correct order (big endian)

Example for calculation with distance value.

0xc0	0xa6	0xb3	0x05	0xed	0xdd	0x80	0x00	0x10
Timestamp				Distance value				Footer

Abb. 34 Received data frame

Distance hex format	0xed	0xdd	0x80	0x00
Distance binary, little-endian	1110 1101	1101 1101	1000 0000	0000 0000
Binary, without flag bit	110 1101	101 1101	000 0000	000 0000
Binary, big endian	000 0000	000 0000	101 1101	110 1101
As unsigned integer	(0000) 0000	0000 0000	0010 1110	1110 1101
Decimal	12013			
As distance	1201.3 mm			

Abb. 35 Transformed distance value

i The sensor can continue to supply measured values to the RS422 output even while the sensor is communicating.

The IF2001 converter from MICRO-EPSILON, which is connected to the sensor via the PC3800-x standard cable (also optional), is suitable for data exchange with a PC, see [Chap. A 1](#). The IF2008/ETH is suitable for recording data in a synchronized manner from multiple sensors. You can find more information in the descriptions of the IF2008/ETH interface card and the relevant MEDAQLib driver program.

You can find the current program routine at: www.micro-epsilon.de/link/software/medaqlib.

8.3 Binary error values

Status information transmitted in the distance value.

Distance value	Description
0x7ffc87	Invalid measurement result
0x7ffccd	Timeout in laser module communication
0x7ffcce	Laser module command interrupted
0x7ffccf	Device busy
0x7ffcd0	Command error in laser module communication
0x7ffcd1	Tracking measurement period too short
0x7ffcd2	Error in laser module communication
0x7ffcd3	Distance outside the measuring range
0x7ffcd4	Temperature too high
0x7ffcd5	Temperature too low
0x7ffcd6	Signal too weak or distance not in permissible range
0x7ffcd7	Signal too high
0x7ffcd8	Signal noise
0x7ffcd9	Laser module voltage too low
0x7ffcda	Signal too unstable
0x7ffcdb	Laser not in measurement mode
0x7ffcdc	Temperature gradient too high
0x7ffe70	Start of ROI is larger than end of ROI

8.4 Resetting the sensor

You can reset the sensor to the factory setting. To do this, half the supply voltage must be applied to the trigger input. Due to the 47 kOhm internal pull-down resistor, you simply have to connect the TRIG connection to U_B via a 47 kOhm resistor.

This function executes a complete reset of the sensor and takes about 5 seconds. The delivery firmware is loaded and the sensor is reset to the factory settings. This function can also be used if the firmware is damaged, e.g. if the update process is faulty.

Abb. 36 Resetting to factory setting

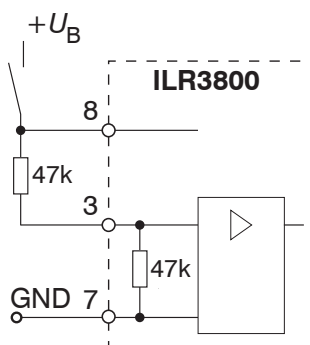

9. Cleaning

We recommend cleaning the protective glass at regular intervals.

Dry cleaning

This can be accomplished with an anti-static lens brush or by blasting the windows with dehumidified, clean, oil-free compressed air.

Wet cleaning

Use a clean, soft, lint-free cloth or lens cleaning paper and pure alcohol (isopropyl alcohol) to clean the protective glass pane.

Never use commercially available glass cleaner or other cleaning agents.

10. Software support with MEDAQLib

MEDAQLib is a documented driver DLL. This allows you to integrate sensors from MICRO-EPSILON in conjunction with a converter or interface module into existing or customer-specific PC software.

MEDAQLib

- contains a DLL that can be imported into C, C++, VB, Delphi and many other programs,
- takes care of data conversion for you,
- works regardless of the type of interface used,
- uses the same functions for communication (commands),
- provides a uniform transmission format for all Micro-Epsilon sensors.

For C/C++ programmers, an additional header file and a library file are integrated into MEDAQLib.

You can find the current driver routine including documents at:

www.micro-epsilon.com/service/download

www.micro-epsilon.com/link/software/medaqlib/

11. Disclaimer

All components of the device have been checked and tested for functionality in the factory. However, should any defects occur despite careful quality control, these shall be reported immediately to Micro-Epsilon or to your distributor / retailer.

Micro-Epsilon undertakes no liability whatsoever for damage, loss or costs caused by or related in any way to the product, in particular consequential damage, e.g., due to

- non-observance of these instructions/this manual,
- improper use or improper handling (in particular due to improper installation, commissioning, operation and maintenance) of the product,
- repairs or modifications by third parties,
- the use of force or other handling by unqualified persons.

This limitation of liability also applies to defects resulting from normal wear and tear (e.g., to wearing parts) and in the event of non-compliance with the specified maintenance intervals (if applicable).

Micro-Epsilon is exclusively responsible for repairs. It is not permitted to make unauthorized structural and / or technical modifications or alterations to the product. In the interest of further development, Micro-Epsilon reserves the right to modify the design or the firmware. In addition, the General Terms of Business of Micro-Epsilon shall apply, which can be accessed under Legal details | Micro-Epsilon

<https://www.micro-epsilon.com/legal-details/?sLang=en>.

12. Service, repair

If the sensor or sensor cable is defective:

- If possible, save the current sensor settings in a parameter set to reload them into the sensor after the repair, see [Chap. 6.9.1](#).
- Please send us the affected parts for repair or exchange.

If the cause of a fault cannot be clearly identified, please send the entire measuring system to:

MICRO-EPSILON Eltrotec GmbH
Manfred-Wörner-Straße 101
73037 Göppingen / Germany

Tel. +49 (0) 7161 / 98872-300
Fax +49 (0) 7161 / 98872-303
e-mail info@micro-epsilon.com
www.micro-epsilon.com

13. Decommissioning, disposal

In order to avoid the release of environmentally harmful substances and to ensure the reuse of valuable raw materials, we draw your attention to the following regulations and obligations:

- Remove all cables from the sensor and/or controller.
- Dispose of the sensor and/or the controller, its components and accessories, as well as the packaging materials in compliance with the applicable country-specific waste treatment and disposal regulations of the region of use.
- You are obliged to comply with all relevant national laws and regulations.







For Germany / the EU, the following (disposal) instructions apply in particular:

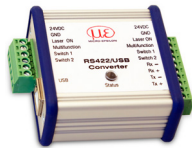

- Waste equipment marked with a crossed garbage can must not be disposed of with normal industrial waste (e.g. residual waste can or the yellow recycling bin) and must be disposed of separately. This avoids hazards to the environment due to incorrect disposal and ensures proper recycling of the old appliances.
- A list of national laws and contacts in the EU member states can be found at https://ec.europa.eu/environment/topics/waste-and-recycling/waste-electrical-and-electronic-equipment-weee_en. Here you can inform yourself about the respective national collection and return points.
- Old devices can also be returned for disposal to Micro-Epsilon Eltrotec GmbH, Manfred-Wörner-Str. 101, 73037 Göppingen / Germany.
- We would like to point out that you are responsible for deleting the measurement-specific and personal data on the old devices to be disposed of.
- Under the registration number WEEE Registration No. DE56585550, we are registered at the foundation Elektro-Altgeräte Register, Nordostpark 72, 90411 Nuremberg, as a manufacturer of electrical and/or electronic equipment.



Appendix

A 1 Optional accessories

IF2001/USB		Converter from RS422 to USB, type: IF2001/USB, suitable for PC3800-x cable, including driver, Connections: 1x 10-pin socket strip (cable clamp), type: Würth 691361100010; 1x 6-pin socket strip (cable clamp), type: Würth 691361100006
IF2004/USB		4-channel converter from RS422 to USB, suitable for PCF3800-x/IF2004 cable, including driver, Connections: 2 x sub-D, 1 x terminal block
IF2008/ETH		8-channel RS422/Ethernet converter with industrial M12 plug/socket suitable for PCE3800-x cable
PS2020		Power supply for DIN rail installation, input 230 VAC, output 24 VDC/2.5 A
Dual Processing Unit		Interface module for the synchronous acquisition and processing of two sensor values or for digital-to-analog conversion; module inputs can be switched via software (encoder or RS422 input)
IF2035/PROFINET IF2035/EIP IF2035/ECAT		Interface module for PROFINET, EtherCAT, or Ethernet connection of a Micro-Epsilon sensor with an RS485 or RS422 interface; compatible with PC3800-x and PC3800/90-x cables; DIN rail housing; includes GSDML file for software integration into the PLC
PC3800-x ¹		Supply/output cable, x m long, for optoNCDT ILR 3800 series, straight plug, M16 12-pin plug; 3, 5, 10, 20, 25, 30, 40, 50 m long with open ends (not tin-plated)
PC3800/90-x ¹		Supply/output cable, x m long, for optoNCDT ILR3800 series, with 90° angle socket; M16 12-pin plug; 3, 5, 10, 20, 30, 40 m long with open ends (not tin-plated)
PCF3800-3/IF2004		Supply/output cable, 3 m long, for 4-channel IF2004/USB converter, with M16 connector and 15-pin Sub-HD plug
PCE3800-x		Supply/output cable, x m long, for 8-channel IF2008/ETH converter, with M16 and M12 connectors
PCE3800-3/IF2008ETH		Connection cable between ILR3800-100 and IF2008/ETH, length 3 m.
PC3800-x IO-Link		Supply/output cable, x = 5, 10 or 15 m long, 5-pin M12 connector on both sides, connection to IO-Link

1) All lengths are also available in a drag chain-compatible design.		
ILR-TB3800		White-painted sheet metal as an ideal target for distance measurements.
ILR-RF210		Reflective film, for measurements up to 150 m away
ILR-PG3800 protective glass		Optical glass, with anti-reflection coating and high transmission
ILR-NDF3800 filter glass		Optical gray filter, reduces maximum laser power. Enables measurement on strongly reflecting surfaces. It is possible to reduce the measuring range. Ask your regional sales contact before you use the filter glass.
ILR-MP3800 Mounting plate		The sensor can optionally be mounted using an aluminum plate. This ensures a secure hold and easy alignment of the sensor. Its robust design is suitable even for harsh industrial environments. You can find the technical drawing of the mounting plate in see Chap. A 2 .
ILR-DLS3800 Compressed-air purge system		For cleaning or permanently keeping the optical path clear.

A 2 Mounting plate

The sensor can optionally be mounted using a mounting plate. This consists of a mounting plate and an alignment plate, which are pre-assembled at the factory as a complete alignment system.

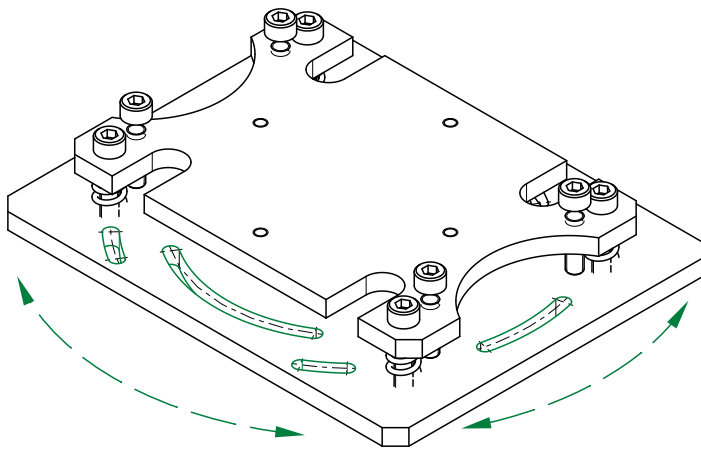

The sensor can optionally be mounted using a mounting plate.

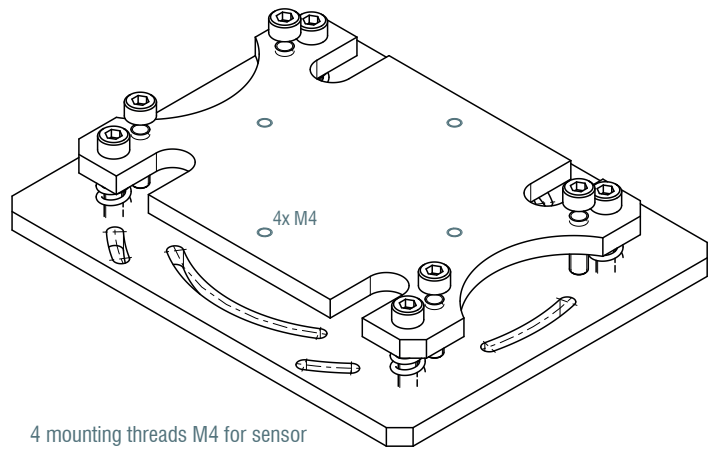

4 mounting threads M4 for sensor mounting, optional: sensor rotated by 90°.

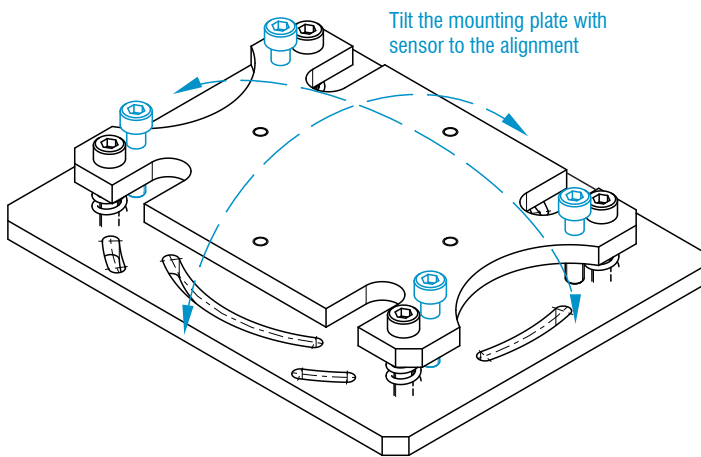

Tilt the mounting plate with sensor to the alignment



Abb. 37 Dimensional drawing of mounting plate ILR-MP3800, dimensions in mm

A 3 Factory settings

A 3.1 ILR3800-100

Preset	Automatic
Baud rate	115200 baud
Laser	Measure
Region of interest	0.0 mm (min) 150000.0 mm (max)
Analog output scaling	50 mm (min) 8000 mm (max)
MFI	Inactive
RS422	Timestamp and distance value

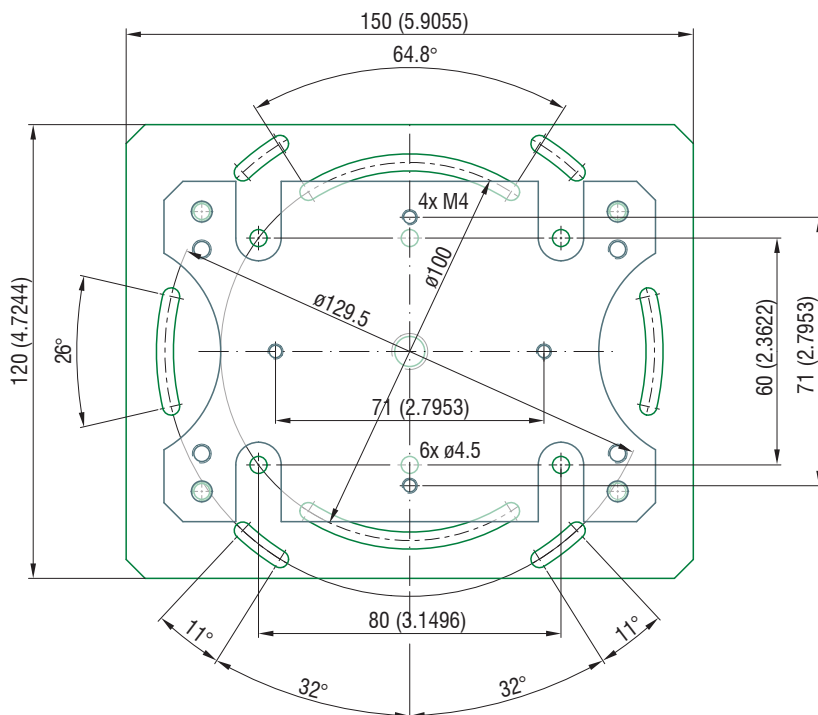
A 3.2 ILR3800-100-IO

Preset	Automatic
Transmission speed	COM2 (38.4 kBaud)
Laser	Measure
Region of interest	0.0 mm (min) 150000.0 mm (max)

A 4 ASCII Communication with Sensor

A 4.1 General

The ASCII commands can be sent to the sensor via the RS422 interface. All commands, inputs and error reports are in English. A command always consists of the command name and zero or several parameters that are separated with a space and end in LF. If spaces are used in parameters, the parameter must be placed in quotation marks, e.g. "Password with space".

Example: Switching on output via RS422

OUTPUT RS422 ↵

Note: ↵ Must contain LF, but can also be CR LF.

Explanation: LF Line feed (hex 0A)

CR Carriage return (hex 0D)

↵ Enter (depending on system, hex 0A or hex 0D0A)

The currently set parameter value is returned when a command is called without any parameters.

The entry formats are:

```
<Command name> <Parameter1> [<Parameter2> [...]]
```

```
<Command name> <Parameter1> <Parameter2> ... <Parameter...>
```

or a combination thereof.

Parameters in [] brackets are optional and require you to enter the preceding parameter.

Successive parameters without [] brackets are required, i.e. no parameter can be omitted. Alternative entries for parameter values are separated by "|", e.g. the values "a", "b" or "c" can be set for "a|b|c". Parameter values in <> brackets can be selected from a value range.

Explanations on the format:

"a b"	Parameter value can be set to the value "a" or "b".
" P1 P2"	Both parameters "P1" and "P2" must be set.
" P1 [P2 [P3]]"	The parameters "P1", "P2" and "P3" can be set, whereby "P2" can only be set if "P1" is set and "P3" can only be set if "P1" and "P2" are set.
"<a>"	Parameter value is within a value range of "... to ...", see parameter description.

Parameter values without angle brackets can only be discrete values, see parameter description. Round brackets should be interpreted as a grouping, i.e. for better comprehensibility, "P1 P2|P3" is written as "(P1 P2)|P3".

Example without []:

```
„PASSWD <Old password> <New password> <New password>“
```

- All 3 parameters must be entered in order to change the password.

The output format is:

```
<Command name> <Parameter1> [<Parameter2> [...]]
```

The response can be used again without changes as a command for setting the password. Optional parameters are only returned as well if this is necessary. For example, for the data selection additional values command, only the activated output values are returned.

After a command is processed, a line break and a prompt ("->") is always returned. In the event of an error, an error message beginning with "Exxx", where xx stands for a unique error number, comes before the prompt. Moreover, instead of error messages, warning messages ("Wxxx") may be output. Warnings are structured analogously to error messages. In the case of warning messages, the command has been executed.

For support requests regarding the sensor, the responses to the commands GETINFO and PRINT are helpful because they contain the sensor settings.

A 4.2 Commands overview

Group	Chapter	Command	Brief description
General			
	Chap. A 4.3.1	HELP	Help on commands
	Chap. A 4.3.2	GETINFO	Request sensor information
	Chap. A 4.3.3	GETTEMP	Determine sensor temperature
	Chap. A 4.3.4	PRINT	Output of all sensor settings
	Chap. A 4.3.5	PRINT ALL	Output of measurement settings and sensor information
	Chap. A 4.3.6	RECOVERY	Resetting the sensor firmware
	Chap. A 4.3.7	RESET	Reboot sensor
	Chap. A 4.3.8	RESETCNT	Reset counter
MFI input			
	Chap. A 4.3.9	MFIFUNC	Multifunction input
	Chap. A 4.3.10	TRIGGER	Set trigger mode
	Chap. A 4.3.11	TRIGGERAT	Effect of trigger input
	Chap. A 4.3.12	TRIGGERLEVEL	Select level for switching input
	Chap. A 4.3.13	TRIGGERCOUNT	Number of measured values to be specified
	Chap. A 4.3.14	TRIGGERSW	Software trigger pulse
	Chap. A 4.3.15	MASTERSET	Mastering / zeroing
	Chap. A 4.3.16	MASTERSIGNAL	Corresponds to the difference between the measured value and the master signal <distance>
Interfaces			
	Chap. A 4.4.1	BAUDRATE	Set transmission rate of RS422
Setup and Measurement Settings			
	Chap. A 4.5.1	MEASSETTINGS	Load/save measurement settings
	Chap. A 4.5.2	BASICSETTINGS	Load/save device settings
	Chap. A 4.5.3	SETDEFAULT	Factory settings
	Chap. A 4.5.4	LASER	Switch on measurement laser, start measurement
	Chap. A 4.5.5	ROI	Mask the region of interest (ROI)
Data output			
	Chap. A 4.6.1	OUTPUT	Measured value output selection
	Chap. A 4.6.2	GETOUTINFO_ RS422	List intended data for RS422
	Chap. A 4.6.3	OUTADD_RS422	Data selection of additional values
	Chap. A 4.6.4	ANALOGSCAL- ERANGE	Analog output scaling limits

A 4.3 General commands

A 4.3.1 HELP

```
HELP [<command>]
```

Output help for each command.

Command without parameters

```
<Command> // Command is executed
```

Command with parameters

```
<Command>
```

```
// Show current parameter values
```

```
<Command> <Parameter1> [<Parameter2> [...]]
```

```
// Set the parameters; the number of
// parameters varies
```

```
<Command> <Parameter1> <Parameter2> ... <Parameter...>
```

```
// Set the parameters; the number of
// parameters stays the same
```

Response to a command

```
-> Cursor; the sensor is waiting for an entry
```

```
E<ddd> Error message; execution rejected
```

```
<ddd> Error code
```

Format explanation

```
() Grouping
```

```
[] Optional parameters
```

```
<> Placeholders
```

```
| Alternative
```

If a parameter contains spaces, they must be placed in quotation marks.

Examples:

```
a|b // Use a or b
```

```
a b // Both parameters are required
```

```
a [b [c]] // Non-fixed number of parameters: a, a b, or a b c
```

A 4.3.2 GETINFO

```
GETINFO
```

Request sensor information. Output see example below:

->GETINFO		
Name:	ILR3800	//Model name of sensor
Serial:	1252	//Serial number
Option:	000	//Sensor option number
Article:	7112028	//Sensor article number
Measuring range:	150000.0 mm	//Measuring range of sensor
Version:	1.0	//Software version
Bootloader version	1.3.0	//Current software version
Hardware-rev:	00	
->		

A 4.3.3 GETTEMP

```
GETTEMP
```

Reports the inner temperature of the sensor in °C with one decimal place.

A 4.3.4 PRINT

PRINT

Print is used to output all measurement settings. Example of a response:

```
BAUDRATE 115200
LASER OFF
ROI 0.0 150000.0
OUTPUT RS422
ANALOGSCALERANGE 50.0 8000.0
MFIFUNC TRIGGER
MASTER INACTIVE
MASTERSIGNAL 0.0
TRIGGER NONE
TRIGGERAT OUTPUT
TRIGGERCOUNT
TRIGGERLEVEL HIGH
GETOUTINFO_RS422 TIMESTAMP DIST1
OUTADD_RS422 TIMESTAMP
OUTHOLD NONE
MEASSETTINGS PRESETMODE AUTO
->
```

A 4.3.5 PRINT ALL

PRINT ALL

This command combines the two `GETINFO` and `PRINT` commands. In addition to the current measurement settings, the sensor information is also output.

A 4.3.6 RECOVERY

RECOVERY [RECOVERY]

Reads out information about the recovery safety image.

[RECOVERY LOAD]

Resets the firmware to the recovery image. The sensor is restarted for this purpose.

A 4.3.7 RESET

RESET

The sensor is restarted.

A 4.3.8 RESETCNT

RESETCNT TIMESTAMP

Resets the internal timestamp in the sensor.

A 4.3.9 MFIFUNC

MFIFUNC [NONE TRIGGER MASTER]

Select the function of the multifunction input:

- NONE: Multifunction input has no function
- TRIGGER: Multifunction input is a trigger input
- MASTER: Multifunction input starts the mastering.

A 4.3.10 TRIGGER

TRIGGER [NONE|EDGE|PULSE|SOFTWARE]

Selection of trigger type.

- NONE: No triggering
- EDGE: Edge triggering
- PULSE: Level triggering
- SOFTWARE: Software triggering

A 4.3.11 TRIGGERAT

TRIGGERAT [INPUT|OUTPUT]

Defines the type of triggering for data acquisition or data output.

- INPUT: Triggers data acquisition.
- OUTPUT: Triggers measured value output.

A 4.3.12 TRIGGERLEVEL

TRIGGERLEVEL [HIGH|LOW]

Defines the active level of a trigger event.

- HIGH: HIGH: Edge triggering: Rising edge, level triggering: High active
- LOW: Edge triggering: Falling edge, level triggering: Low active

A 4.3.13 TRIGGERCOUNT

TRIGGERCOUNT [<n> | INFINITE]

Sets the number of measured values to be output during triggering.

- INFINITE: Start of continuous output after first trigger event
- <n>: Number of values to be output after each trigger event n = 1 to 2147483646.

A 4.3.14 TRIGGERSW

TRIGGERSW

Generates a software trigger pulse.

A 4.3.15 MASTER SET

MASTER SET

Executes the Master function. An offset for the subsequent measurement values is determined using the current measurement value and the measurement value from the master signal (see `MASTERSIGNAL`). Measurements at the distance set in the master signal <distance> therefore result in a measured value that corresponds to the master signal.

If the master value is 0, mastering has the same function as zeroing.

A 4.3.16 MASTERSIGNAL

MASTERSIGNAL | MASTERSIGNAL <distance>

- MASTERSIGNAL: Reads out the currently configured master signal value.
- MASTERSIGNAL <distance>: Sets the distance value in the master signal to a defined distance.

A 4.4 Interfaces

A 4.4.1 BAUDRATE

```
BAUDRATE [9600|115200|230400]
```

Sets the baud rate for the RS422 interface.

A 4.4.2 OUTHOLD

```
OUTHOLD [NONE|0|<count>]
```

Sets the measured value output behavior in the event of an error.

- NONE: Last measured value not held; error value output.
- 0: Last measured value held indefinitely
- <count> Holds the last measured value for n measurement cycles; after that, an error value is output.
n = (1 ... 2147483645).

A 4.5 Setup and measurement settings

A 4.5.1 MEASSETTINGS

```
MEASSETTINGS [READ|STORE|PRESETLIST|PRESETMODE [<mode>]]
```

Settings for measurement task. Loads manufacturer-defined presets or user-specific setups from the sensor or saves user-specific setups in the sensor.

- READ: Read measurement settings from non-volatile memory.
- STORE: Write measurement settings to non-volatile memory.
- PRESETLIST: Lists all existing configurations
- PRESETMODE: Sets a configuration
- <mode>: Name of a configuration listed with the subcommand PRESETMODE.

A 4.5.2 BASICSETTINGS

```
BASICSETTINGS [READ|STORE]
```

- READ: Loads the saved device settings from the sensor.
- STORE: Saves the current device settings in the sensor.

A 4.5.3 SETDEFAULT

```
SETDEFAULT MEASSETTINGS
```

Resets the sensor to factory settings.

- ALL: Deletes the measurement and device settings and loads the standard presets for the measurement settings and default parameters for the device settings.
- MEASSETTINGS: Deletes the measurement settings and loads the standard presets.
- BASICSETTINGS: Deletes the device settings and loads the default parameters.

A 4.5.4 LASER

```
LASER [OFF|MEASURE]
```

- OFF: Switches the laser off, ends the measurement.
- MEASURE: Starts a measurement.

A 4.5.5 ROI

```
ROI [<lower> <upper>]
```

Sets the region of interest; the value range for min and max is between the SMR and EMR. The value "min <lower>" is less than the value "max <upper>".

<lower> Value range between SMR and EMR (mm, one decimal place)

<upper> Value range between SMR and EMR (mm, one decimal place)

A 4.6 Data output

A 4.6.1 OUTPUT

```
OUTPUT [NONE|RS422|RS422_ASCII]
```

Output of measurement results to serial interface.

- NONE: No output of measured values.
- RS422: Binary output of measured values via RS422.
- RS422_ASCII: Output of measured values via RS422 using ASCII.

A 4.6.2 GETOUTINFO_RS422

```
GETOUTINFO_RS422
```

The command lists all output data selected for the RS422 interface. The order shown corresponds to the output order.

A 4.6.3 OUTADD_RS422

```
OUTADD_RS422 NONE | TIMESTAMP | TEMPERATURE | TIMESTAMP TEMPERATURE
```

Selection of additional values to be transmitted.

- NONE: No output of any further values
- TIMESTAMP: Outputs the time stamp
- TEMPERATURE: Temperature is output in addition the measured value
- TEMPERATURE TIMESTAMP: Time stamp and temperature are output in addition to the measured value

A 4.6.4 ANALOGSCALERANGE

```
ANALOGSCALERANGE [<lower> <upper>]
```

Sets the scaling limits for the analog output during two-point scaling.

Value range:<limit 1> = (-2 ... +2) * Measuring range [mm] <limit 2> = (-2 ... +2) * Measuring range [mm]

The scaling limits must not be identical; <lower> is less than <upper>.

<lower> Value range between SMR and EMR (mm, one decimal place)

<upper> Value range between SMR and EMR (mm, one decimal place)

A 4.7 ASCII Error Codes

Error code	Description
E104	Timeout
E110	Processing of configuration failed
E111	Measurement result invalid
E112	Error while executing command
E180	Internal error in laser module communication
E181	Timeout in laser module communication
E182	Laser module command interrupted
E183	Device busy
E184	Command error in laser module communication
E185	Tracking measurement time too short
E186	Error in laser module communication
E187	Distance not in measurement range
E188	Temperature too high
E189	Temperature too low
E190	Signal too low or distance not in range
E191	Signal too high
E192	Signal too noisy
E193	Laser module voltage too low
E194	Signal too unstable
E195	Laser not in measurement mode
E196	Temperature gradient too high
E204	Invalid character in input
E210	Unknown command keyword
E214	Entered command is too long to be processed
E215	Input or command buffer overflow
E234	Missing/unexpected parameters or wrong parameter type
E236	Invalid parameter value
E363	Setting is invalid
E600	ROI begin is greater than roi end
E616	Software triggering is not active



MICRO-EPSILON Eltrotec GmbH
Manfred-Wörner-Straße 101 · 73037 Göppingen / Germany
Tel. +49 (0) 7161 / 98872-300 · Fax +49 (0) 7161 / 98872-303
info@micro-epsilon.com · www.micro-epsilon.com
Your local contact: www.micro-epsilon.com/contact/worldwide/

X9751490-B012036TSw
© MICRO-EPSILON MESSTECHNIK